

Annual Report for the year 2019
The Parish of Saint George
Halifax, Nova Scotia



Annual General Meeting: February 23, 2020

Table of Contents

| | |
|---|-------|
| Agenda for the Annual General Meeting, February 23, 2020 | p. 1 |
| Minutes of the Annual General Meeting, February 24, 2019..... | p. 2 |
| Year End 2019 Financial Statements | |
| Parish Corporation | |
| Income and Expense Statement | p. 6 |
| Balance Sheet | p. 10 |
| Deck the Hall..... | p. 13 |
| Refugee Sponsorship Committee | p. 13 |
| Insurance Documents..... | p. 14 |
| Rector's Report..... | p. 15 |
| Wardens' Report..... | p. 17 |
| Parish Administrator's Report | p. 18 |
| Music Director's Report | p. 19 |
| Reports from Committees, Subcommittees, Parish Organizations, and Congregational Bodies | |
| <i>Spiritual Development</i> | |
| i. Spiritual Development Committee | p. 22 |
| ii. Altar Guild | p. 23 |
| iii. Altar Servers..... | p. 23 |
| iv. Parish Library..... | p. 24 |
| v. Sunday School..... | p. 25 |
| <i>Pastoral Ministry & Outreach</i> | |
| vi. Christmas Outreach | p. 26 |
| vii. Deaf Ministry | p. 26 |
| viii. Fellowship..... | p. 26 |
| ix. Refugee Sponsorship Committee | p. 26 |
| x. Shoeboxes for Seafarers | p. 28 |
| xi. Soup Kitchen..... | p. 28 |
| xii. YouthNet..... | p. 30 |
| <i>Property</i> | |
| xiii. Property Committee | p. 32 |
| xiv. Deck the Hall..... | p. 36 |
| xv. Sextons & Trinity House..... | p. 37 |
| <i>Other Parish Activities & Organizations</i> | |
| xvi. Parish Archives | p. 38 |
| xvii. Plant Sale..... | p. 39 |
| Parish Corporation Budget 2020 | p. 40 |
| Nominations for 2020..... | p. 45 |
| Baptisms, Confirmations, Marriages, and Funerals at St. George's in 2019..... | p. 45 |

Parish of St George
Annual General Meeting
February 23, 2020

Agenda as per Canon 35

1. Opening prayer
2. The Election of the Chair of the Meeting
3. The Election of the Secretary of the Meeting
4. Reading, correction, and approval of minutes of the previous meeting held February 24, 2019
5. Business arising from the minutes
6. Correspondence
7. Financial Report
 - a. Income and Expenses for 2019
 - b. Balance Sheet at year-end 2019
8. Presentation of all insurance policies
9. New business;
10. Rector's Report
11. Wardens' Report
12. Parish Administrator's Report
13. Music Director's Report
14. Committee and Group reports

Spiritual Development

- i. Spiritual Development Committee
- ii. Altar Guild
- iii. Altar Servers
- iv. Parish Library
- v. Sunday School

Pastoral Ministry & Outreach

- vi. Christmas Outreach
- vii. Deaf Ministry
- viii. Fellowship
- ix. Refugee Sponsorship Committee
- x. Shoeboxes for Seafarers
- xi. Soup Kitchen
- xii. YouthNet

15. Presentation from the Friends of Saint George's Society
16. Presentation of Budget for 2020
17. Elections:
 - i. Warden
 - ii. Members of Parish Council
 - iii. Youth delegates to Synod
 - iv. Secretary
18. Closing Prayer

Property

- xiii. Property Committee
- xiv. Deck the Hall
- xv. Sextons & Trinity House

Other Parish Activities & Organizations

- xvi. Parish Archives
- xvii. Plant Sale

- v. Treasurer
- vi. Auditors
- vii. Delegates to Regional Council

Parish of St George
Annual General Meeting
February 24, 2019

Agenda as per Canon 35

1. Opening prayer; led by Fr. Hatt
2. The Election of the Chair of the Meeting;

MOTION: J de Mestral nominated Fr. Hatt as chair of the meeting; Second: S Zink; Carried

3. The Election of the Secretary of the Meeting;

MOTION: J de Mestral nominated J Gracie as secretary of the meeting; Second; Carried.

4. The reading, correction, if any, and approval of the minutes of the previous meeting dated February 25, 2018;
 - a. Amendments: none

MOTION: P Martinson moved that the minutes be accepted as circulated; Second: J Connors; Carried.

5. Any unfinished business from the previous annual meeting;
 - a. Discussion of an illuminated sign (Fr. Hatt reporting). Parish Council is discussing the ways and means of redesigning the parish's exterior signage.
 - b. Discussion of the Halifax Community Chaplaincy: last year the Halifax Community Chaplaincy requested funds from the Parish. The item was sent to Parish Council, which approved sending \$500 per year for three years, 2018, 2019, and 2020
 - c. William Shaw brought up the addition of handrails to the staircases in the parish hall. The project to add the handrails was completed in 2018. Thanks to A Snook and J Gracie for their work, and thanks to B Mullin for his work fabricating the rails.

6. Business arising from the minutes;

7. Communications;
 - a. None

8. Consideration of the Statement of Financial Position at Year-End 2018 (D Wright reporting)
 - a. Line 7 shows that the parish received \$229,720.29 in undesignated offerings in 2018;
 - b. Line 28 shows that the parish received a total of \$264,442.20 in both designated and undesignated offerings;
 - c. Line 37 shows that the parish received \$17,352.71 in cash from its endowments in 2018;
 - d. Line 47 shows a grant income of \$40,621.47. This is a combination of the Parks Canada grant for the restoration of the chancel windows, the Canada Summer Jobs grant, and a grant to complete an architectural assessment of the Little Dutch Church graveyard walls;
 - e. Line 181 shows total expenses of \$374,568.39; and
 - f. Line 187 shows a net income of \$781.08

Fr. Hatt expressed thanks to the Treasurer, D Wright.

MOTION: P Martinson moved the acceptance of the 2018 year-end financial statement as presented; Second: S Zinck; Carried.

9. The presentation of a list of all insurance policies belonging to the parish corporation and the amount of insurance on all buildings owned by the parish corporation;

- a. Diocese has advised that the paperwork is not yet ready, and has supplied a memo (found on page 36) for inclusion in Parochial Annual Reports.

10. New business;

- a. Regarding Direct Debit Offerings (P Martinson): There are around 30 people who give to the parish by Direct Debit, who have also received physical offering envelopes. In order to reduce the parish's operating expenses, those who give to the parish through Direct Debit should discontinue their envelopes

ACTION ITEM: the Rector, Wardens, Treasurer and Envelope Secretary will address this.

11. The presentation of the Statement of Income and Expense for the year 2018;

- a. The Parish Corporation;
 - i. Covered under item 8.
- b. Deck the Hall;
 - i. Deck the Hall incurred one major expense in 2018: the cost of heating lines from the natural gas boilers in the west furnace room to the Annex forced air unit.
- c. The Refugee Sponsorship Committee;
 - i. The loan of 6 months' rent that the Refugee Sponsorship Committee issued to the Hussein family was repaid in full in 2018.

MOTION: M Hills moved the acceptance of the financial reports of Deck the Hall and the Refugee Sponsorship Committee; Second: V Mowat; Carried.

12. The report of the Rector;

- a. Looking ahead to 2019, June 2 of 2019 is the 25th anniversary of the fire, which severely damaged the Round Church. At the Rector's induction, M Frances encouraged the parish think on the ministries that we have and of ways to expand on them.

The Rector expressed thanks to every person at the head table: The Wardens, Treasurer, Parish Administrator, Music Director, Chair of Finance, and Director of YouthNet. This was greeted with a round of applause.

13. The report of the Wardens (J de Mestral reporting);

- a. J de Mestral expressed thanks to the other Wardens, Treasurer, Parish Administrator, Finance Chair, and the Rector, and announced that E King will be resigning as Warden in 2019 due to his moving away.

14. Consideration of a written report of each committee of the parish and the reception of reports of parish organizations, regional council, and other congregational bodies;

- a. Spiritual Development Committee: S Harris, who is stepping down as Chair of the Spiritual Development Committee expressed that it has been a pleasure to serve as Chair.

The meeting expressed thanks to S Harris for her service with applause.

- b. Sunday School

The chair expressed thanks to M Jamieson for her leadership in the Sunday School. This was greeted with applause from the meeting.

- c. Altar Guild: (T Lenfesty reporting) Two members of the Altar Guild were lost in 2018: B Naftel, who, among other things, always made sure the pew numbers were polished, and B Richardson, who loved arranging the altar flowers.
- d. Property: (U vom Hagen reporting): 2018 was an active year for property. The committee achieved a large number of things, but could not handle every outstanding issue.

The Chair of Property expressed thanks to the Parish Administrator and J de Mestral, Warden.

- e. Deaf Ministry (S Harris reporting)
- f. Shoeboxes for Seafarers: (P Martinson reporting)

P Martinson expressed thanks to all who have donated to the Shoeboxes for Seafarers Campaign, and reminded those assembled that cash donations are wonderful in the spring and summer. P Martinson then expressed thanks to Anne Tilley her work coordinating the campaign.

- g. Trinity House

The residents of Trinity House expressed thanks to the Property Committee for addressing many of the maintenance issues with the building.

- h. Archives (T Dawson reporting): If you have any memorabilia from the fire, please consider donating those items to the Archives. The Archives would like to compile an exhibit of Anne West's materials regarding the fire and reconstruction.

J de Mestral expressed thanks to M King and T Urquhart for coordinating the Books & More Sale, and reminded those assembled that the annual plant sale is set to take May 31 and June 1, 2019.

- i. Christmas Outreach

The Chair Thanks to the Himmelmans, K Lickers, and S Connors and to everyone who donated, wrapped, packed and delivered.

- j. Music Director

- k. Finance

D Wright, Treasurer, expressed thanks to J Connors, past Treasurer, and T Lenfesty, Warden, for their support during this first year with a new Treasurer. D Wright also expressed a need for more volunteers to help count the offering.

- l. Altar Servers

Fr. Hatt Expressed thanks to S Connors for scheduling the servers

MOTION: P Dawson moved the acceptance of the reports of the Rector, Wardens, committees, parish organizations, regional council, and other congregational bodies; Second: S Harris; Carried.

- 15. Presentation from the Friends of Saint George's Society (S Harris, *President, Friends of Saint George's Society*)
 - a. A written report was read to the assembled peoples.
 - b. The Friends of Saint George's Society was founded to support activities in the parish which are particular to us as a BCP parish.

- 16. Consideration of a statement of the estimated income and expenditures for the ensuing year (**Budget 2019**);

Motion: J M Dawson moved the adoption of the 2019 budget one amendment: the budget for Deaf Ministry Interpreters, found on line 92, is to be increased from \$4,400 to \$5,500; Second: S Zinck; Carried

17. The election of Wardens;
 - a. Nominated: J de Mestral and N McAllister; Elected by acclamation
18. The election of other members of Parish Council;
 - a. Nominated: A Bickerton, G Wilmhoff, S Landry, S Gibson, J Wollf; Elected by acclamation.
19. The election of lay representatives and youth delegates to Synod pursuant to the Constitution of the Synod;
 - a. Nominated: S Zinck;

MOTION: P Martinson moved that Parish Council be empowered to elect lay representatives and youth delegates to Synod; Second: S Zinck; Carried.

20. The election of a secretary of the parish, unless a meeting of the members of the parish has authorized the parish council established for the parish to elect or appoint the secretary or the by-laws of the parish provide for the appointment of a secretary other than by election at an annual meeting of the members of the parish;
 - a. Appointed by Parish Council
21. The election of a treasurer of the parish, unless a meeting of the parish has authorized the parish council established for the parish to elect or appoint the treasurer or the by-laws of the parish provide for the appointment of a treasurer other than by election at an annual meeting of the members of the parish;
 - a. Appointed by Parish Council
22. The election of one or more auditors;
 - a. U vom Hagen and P Dawson were appointed by Parish Council to audit the 2018 financial statement.

Motion: S Zinck moved that Parish Council be empowered to appoint auditors for 2019; Second: J M Dawson; Carried.

23. The election of delegates to Regional Council (all clergy are members ex officio; at least one synod delegate, between three and six additional members representing men, women and youth);

Motion: S Harris moved that Parish Council be empowered to appoint delegates to Regional Council in 2019; Second: J Connors; Carried.

24. The election of a correspondent to the Diocesan Times;
 - a. No candidates at this time.
25. Such other elections or appointments as the meeting determines;

U vom Hagen expressed thanks to S Harris for coordinating Daily Office Officiants, a task for which the Rector has resumed responsibility.

26. A closing prayer, led by Father Hatt

The chair expressed thanks to M Hills and the fellowship teams for the food, not just today, but throughout the year, and especially for the Viola Desmond event. This was greeted with a standing ovation.

27. Closing prayer led by Fr. Hatt.

Parish of Saint George Year End 2019 Financial Statements

2019 Year End Income & Expense (Unaudited)

| Income & Expenses 2019 | Line # | Actual | Budget | \$ over Budget | % of Budget |
|---|---------------|-----------------------|---------------------|-----------------------|--------------------|
| Income | 1 | | | | |
| 4000 Contributions | 2 | | | 0.00 | |
| 4010 Undesignated Offerings | 3 | | 235,500.00 | -235,500.00 | 0.00% |
| 4011 Direct Deposit | 4 | 58,080.00 | | 58,080.00 | |
| 4012 Envelope Offerings | 5 | 174,587.20 | | 174,587.20 | |
| 4013 Loose | 6 | 18,099.75 | | 18,099.75 | |
| Total 4010 Undesignated Offerings | 7 | \$250,766.95 | \$235,500.00 | \$15,266.95 | 106.48% |
| 4020 Designated Offerings | 8 | | 34,500.00 | -34,500.00 | 0.00% |
| 40201 Altar Guild | 9 | 1,520.00 | | 1,520.00 | |
| 40202 Archives | 10 | 50.00 | | 50.00 | |
| 40203 Christmas Outreach | 11 | 2,971.25 | | 2,971.25 | |
| 40204 Deaf Ministry | 12 | 435.00 | | 435.00 | |
| 40206 Memorials | 13 | 1,093.25 | | 1,093.25 | |
| 40207 Mission to Seafarers | 14 | 50.00 | | 50.00 | |
| 40208 Missions | 15 | 25.00 | | 25.00 | |
| 40209 Music | 16 | 1,848.25 | | 1,848.25 | |
| 40211 PWRDF | 17 | 1,020.00 | | 1,020.00 | |
| 40212 Rector's Discretionary | 18 | 21,340.90 | | 21,340.90 | |
| 40213 Soup Kitchen | 19 | 8,554.48 ¹ | | 8,554.48 | |
| 40214 Special Projects | 20 | 1,452.75 | | 1,452.75 | |
| 40215 Trinity House | 21 | 4,243.25 | | 4,243.25 | |
| 40216 YouthNet | 22 | 1,035.30 | | 1,035.30 | |
| 40217 Little Dutch Church | 23 | 1,068.96 | | 1,068.96 | |
| Total 4020 Designated Offerings | 24 | \$46,708.39 | \$34,500.00 | \$12,208.39 | 135.39% |
| Total 4000 Contributions | 25 | \$297,475.34 | \$270,000.00 | \$27,475.34 | 110.18% |
| 4100 Earned Revenue | 26 | | | 0.00 | |
| 4110 DNS & PEI Endowment Fund | | | | | |
| Interest | 27 | | | 0.00 | |
| 4111 Altar Guild | 28 | 44.43 | 50.00 | -5.57 | 88.86% |
| 4112 Church Preservation Endowment | 29 | 12,913.01 | 12,500.00 | 413.01 | 103.30% |
| 4113 Deaf endowment | 30 | 1,241.00 | 1,200.00 | 41.00 | 103.42% |
| 4114 Pickford Scholarship | 31 | 599.58 | 450.00 | 149.58 | 133.24% |
| 4115 Rector's Discretionary | 32 | 543.72 | 350.00 | 193.72 | 155.35% |
| 4116 Youth Music ETF Interest | 33 | 2,593.52 | 2,550.00 | 43.52 | 101.71% |
| Total 4110 DNS & PEI Endowment Fund Interest | 34 | \$17,935.26 | \$17,100.00 | \$835.26 | 104.88% |
| 4120 Rental Income | 35 | | | 0.00 | |
| 4121 Church Rental | 36 | 3,685.60 | 1,650.00 | 2,035.60 | 223.37% |
| 4122 Hall Rental | 37 | 10,865.20 | 8,700.00 | 2,165.20 | 124.89% |
| 4123 Parking Rental | 38 | 26,624.50 | 24,000.00 | 2,624.50 | 110.94% |
| Total 4120 Rental Income | 39 | \$41,175.30 | \$34,350.00 | \$6,825.30 | 119.87% |
| 4140 Calendars | 40 | 793.50 | 750.00 | 43.50 | 105.80% |
| 4150 Fund Raising Sales & Events-net | 41 | 4,501.35 ² | 5,500.00 | -998.65 | 81.84% |

¹ Includes \$2000 from the 2019 Feed Nova Scotia Capacity Grant

² Includes \$2376 from the annual Plant Sale.

| Income & Expenses 2019 | Line # | Actual | Budget | \$ over Budget | % of Budget |
|---|---------------|------------------------|---------------------|-----------------------|--------------------|
| 4160 Grant Income | 42 | 31,725.00 ³ | 7,200.00 | 24,525.00 | 440.63% |
| 4170 HST Income | 43 | 8,923.62 | 7,915.00 | 1,008.62 | 112.74% |
| 4180 Church Tours | 44 | 125.00 | | 125.00 | |
| Total 4100 Earned Revenue | 45 | \$105,179.03 | \$72,815.00 | \$32,364.03 | 144.45% |
| 4900 Deferred Revenue to Income | 46 | 6,205.90 | | 6,205.90 | |
| Total Income | 47 | \$408,860.27 | \$342,815.00 | \$66,045.27 | 119.27% |
| Expenses | 48 | | | | |
| 5100 GENERAL PARISH EXPENSES | 49 | | | 0.00 | |
| 5101 Allotment | 50 | 36,555.00 | 36,555.00 | 0.00 | 100.00% |
| 5102 Anglican Foundation Membership | 51 | 50.00 | 50.00 | 0.00 | 100.00% |
| 5103 Archives | 52 | | 1.00 | -1.00 | 0.00% |
| 5104 Bank Service Charges | 53 | 1,111.88 | 692.00 | 419.88 | 160.68% |
| 5105 GST/HST Expense | 54 | 21,147.67 | 15,000.00 | 6,147.67 | 140.98% |
| 5106 Police Record Checks | 55 | 50.00 | 1.00 | 49.00 | 5000.00% |
| 5107 Special Events | 56 | 409.31 | 1,500.00 | -1,090.69 | 27.29% |
| 5109 Treasurer Stipend | 57 | 4,800.00 | 4,800.00 | 0.00 | 100.00% |
| 5120 Office Expenses | 58 | | | 0.00 | |
| 5121 Computers & Equipment | 59 | 866.45 | 500.00 | 366.45 | 173.29% |
| 5122 Office Manager | 60 | 2,256.72 | 4,108.00 | -1,851.28 | 54.93% |
| 5123 Photocopier Lease/Maintenance | 61 | 5,040.70 | 4,700.00 | 340.70 | 107.25% |
| 5124 Supplies & Postage | 62 | 2,034.81 | 1,800.00 | 234.81 | 113.05% |
| 5125 Telecommunication | 63 | 1,893.34 | 1,850.00 | 43.34 | 102.34% |
| Total 5120 Office Expenses | 64 | \$12,092.02 | \$12,958.00 | -\$865.98 | 93.32% |
| 5130 Summer Intern/Guide | 65 | \$6,364.68 | \$7,600.00 | -\$1,235.32 | 83.75% |
| 5140 Synod Travel & Accommodation | 66 | 50.00 | | 50.00 | |
| Total 5100 GENERAL PARISH EXPENSES | 67 | \$82,630.56 | \$79,157.00 | \$3,473.56 | 104.39% |
| 5200 ORDAINED MINISTRY | 68 | | | 0.00 | |
| 5201 Diocesan Events | 69 | | 250.00 | -250.00 | 0.00% |
| 5211 Priest - Assistant Ministry | 70 | 1,205.00 | 1,200.00 | 5.00 | 100.42% |
| 5212 Rector's Cell Phone | 71 | 594.87 | 710.00 | -115.13 | 83.78% |
| 5213 Rector's Housing Allowance | 72 | 22,500.00 | 22,500.00 | 0.00 | 100.00% |
| 5214 Rector's Stipend | 73 | 33,499.44 | 32,752.00 | 747.44 | 102.28% |
| 5215 Rector's Travel Reimbursement | 74 | 4,800.00 | 4,800.00 | 0.00 | 100.00% |
| 5216 Rector's Vacation Replacement | 75 | 370.00 | 1,500.00 | -1,130.00 | 24.67% |
| Total 5200 ORDAINED MINISTRY | 76 | \$62,969.31 | \$63,712.00 | -\$742.69 | 98.83% |
| 5300 PASTORAL MINISTRY | 77 | | | 0.00 | |
| 5310 Christmas Outreach | 78 | 2,811.21 | 2,500.00 | 311.21 | 112.45% |
| 5320 Deaf Ministry Interpreters | 79 | 5,450.00 | 5,500.00 | -50.00 | 99.09% |
| 5330 Missions | 80 | 500.00 | 500.00 | 0.00 | 100.00% |
| 5340 Rector's Discretionary Expenses | 81 | 19,420.69 | 6,000.00 | 13,420.69 | 323.68% |
| 5370 Soup Kitchen | 82 | | | 0.00 | |
| 5371 SK Coordinator / Outreach Support | 83 | 14,256.70 | 14,387.00 | -130.30 | 99.09% |

³ Includes the YCW grant and \$28,500 in grants associated with the restoration of the LDC graveyard wall.

| Income & Expenses 2019 | Line # | Actual | Budget | \$ over Budget | % of Budget |
|---|---------------|-----------------------|--------------------|-----------------------|--------------------|
| 5372 Soup Kitchen Supplies | 84 | 9,644.42 ⁴ | 3,100.00 | 6,544.42 | 311.11% |
| Total 5370 Soup Kitchen | 85 | \$23,901.12 | \$17,487.00 | \$6,414.12 | 136.68% |
| 5390 Transfers to Other Institutions | 86 | 419.00 ⁵ | | 419.00 | |
| PWRDF - disbursed to PWRDF | 87 | 1,020.00 | | 1,020.00 | |
| St George's YouthNet | 88 | 5,000.00 | 5,000.00 | 0.00 | 100.00% |
| Total 5390 Transfers to Other Institutions | 89 | \$6,439.00 | \$5,000.00 | \$1,439.00 | 128.78% |
| Total 5300 PASTORAL MINISTRY | 90 | \$58,522.02 | \$36,987.00 | \$21,535.02 | 158.22% |
| 5400 SPIRITUAL DEVELOPMENT | 91 | | | 0.00 | |
| 5410 General Expenses | 92 | | | 0.00 | |
| 5411 Advertising | 93 | 1,031.00 | 1,500.00 | -469.00 | 68.73% |
| 5412 Gifts | 94 | 1,398.26 | 500.00 | 898.26 | 279.65% |
| 5413 Guest Speakers | 95 | 75.00 | 700.00 | -625.00 | 10.71% |
| 5414 Parish Library | 96 | 65.87 | 100.00 | -34.13 | 65.87% |
| 5415 Prayer Book Calendars | 97 | 675.00 | 650.00 | 25.00 | 103.85% |
| 5416 Lay Readers' Association Fees | 98 | 45.00 | | 45.00 | |
| 5417 Special SD Events/Program Costs | 99 | 644.00 ⁶ | 250.00 | 394.00 | 257.60% |
| Total 5410 General Expenses | 100 | \$3,934.13 | \$3,700.00 | \$234.13 | 106.33% |
| 5430 Music Program | 101 | | | 0.00 | |
| 5431 Music Expenses | 102 | 1,485.00 | 1,750.00 | -265.00 | 84.86% |
| 5432 Musicians | 103 | 5,680.00 | 6,000.00 | -320.00 | 94.67% |
| 5433 Music Director's Stipend | 104 | 25,643.24 | 25,586.00 | 57.24 | 100.22% |
| 5434 Music Director's Vacation Replacement | 105 | 760.00 | 1,200.00 | -440.00 | 63.33% |
| 5435 Pickford Scholarship Award | 106 | 500.00 | | 500.00 | |
| Total 5430 Music Program | 107 | \$34,068.24 | \$34,536.00 | -\$467.76 | 98.65% |
| 5440 Sunday School Program | 108 | | | 0.00 | |
| 5441 Supplies & Materials | 109 | 75.97 | 250.00 | -174.03 | 30.39% |
| 5442 Youth | 110 | 3,900.00 | 4,200.00 | -300.00 | 92.86% |
| Total 5440 Sunday School Program | 111 | \$3,975.97 | \$4,450.00 | -\$474.03 | 89.35% |
| 5460 Altar Guild | 112 | | | 0.00 | |
| 5461 Flowers & Misc. | 113 | 740.86 | 500.00 | 240.86 | 148.17% |
| 5462 Liturgical Supplies | 114 | 8,342.44 ⁷ | 2,000.00 | 6,342.44 | 417.12% |
| Total 5460 Altar Guild | 115 | \$9,083.30 | \$2,500.00 | \$6,583.30 | 363.33% |
| Total 5400 SPIRITUAL DEVELOPMENT | 116 | \$51,061.64 | \$45,186.00 | \$5,875.64 | 113.00% |
| 5500 PROPERTY | 117 | | | 0.00 | |
| 5510 General | 118 | | | 0.00 | |
| 5511 Insurance | 119 | 20,914.00 | 21,000.00 | -86.00 | 99.59% |
| 5512 Security | 120 | | 900.00 | -900.00 | 0.00% |
| Alarm Monitoring & False Alarms | 121 | 1,140.00 ⁸ | | 1,140.00 | |
| Sexton's Evening Rounds | 122 | 883.45 | | 883.45 | |

⁴ Includes \$2000 in spending associated with the 2018 Feed Nova Scotia Capacity Grant, \$2000 in spending associated with the 2019 Feed Nova Scotia Capacity Grant, and \$955 in spending associated with repairs to the dishwasher.

⁵ This money was collected at the Remembrance Evensong held on November 10, 2019, and was given to the Legion Poppy Fund which supports Canada's Veterans and their families.

⁶ Includes costs associated with the Palm Sunday donkey and the parish's Anglican Planet subscription, along with other miscellaneous Spiritual Development expenses.

⁷ Includes \$706 for new cassocks and surplices, \$352 for kneelers for the LDC, and \$4,428 for the new green vestment set.

⁸ Includes \$300 in "false alarm" charges from HRM.

| Income & Expenses 2019 | Line # | Actual | Budget | \$ over Budget | % of Budget |
|--|---------------|-------------------------|--------------------|-----------------------|--------------------|
| Total 5512 Security | 123 | \$2,023.45 | \$900.00 | \$1,123.45 | 224.83% |
| 5513 Fire Protection | 124 | 35.10 | 150.00 | -114.90 | 23.40% |
| 5514 Snow Removal | 125 | 11,400.00 | 11,000.00 | 400.00 | 103.64% |
| 5515 Stormwater Charge | 126 | 113.46 | 250.00 | -136.54 | 45.38% |
| 5516 Waste Management | 127 | 1,244.85 | 1,120.00 | 124.85 | 111.15% |
| 5517 Cost of Generating Rental Income | 128 | | 300.00 | -300.00 | 0.00% |
| Sextons' Event Fees | 129 | 459.00 | | 459.00 | |
| Total 5517 Cost of Generating Rental Income | 130 | \$459.00 | \$300.00 | \$159.00 | 153.00% |
| Total 5510 General | 131 | \$36,189.86 | \$34,720.00 | \$1,469.86 | 104.23% |
| 5520 Parish Hall | 132 | | | 0.00 | |
| 5521 Janitorial | 133 | | | 0.00 | |
| Janitorial Services | 134 | 8,134.34 | 12,000.00 | -3,865.66 | 67.79% |
| Janitorial Supplies | 135 | 2,104.96 | 1,300.00 | 804.96 | 161.92% |
| Total 5521 Janitorial | 136 | \$10,239.30 | \$13,300.00 | -\$3,060.70 | 76.99% |
| 5522 Maintenance & Repairs | 137 | 5,945.55 ⁹ | 3,250.00 | 2,695.55 | 182.94% |
| 5523 Pest Control | 138 | 794.30 | 780.00 | 14.30 | 101.83% |
| 5524 Furnace Cleaning | 139 | 99.00 | 600.00 | -501.00 | 16.50% |
| 5525 Fire Alarm Inspection | 140 | | 350.00 | -350.00 | 0.00% |
| 5526 Utilities | 141 | | | 0.00 | |
| Electric | 142 | 7,130.32 | 6,385.00 | 745.32 | 111.67% |
| Gas | 143 | 11,325.37 | 5,700.00 | 5,625.37 | 198.69% |
| Water | 144 | 1,300.23 | 1,300.00 | 0.23 | 100.02% |
| Total 5526 Utilities | 145 | \$19,755.92 | \$13,385.00 | \$6,370.92 | 147.60% |
| Total 5520 Parish Hall | 146 | \$36,834.07 | \$31,665.00 | \$5,169.07 | 116.32% |
| 5530 Trinity House (Rectory) | 147 | | | 0.00 | |
| 5532 Maintenance & Repairs | 148 | 10,231.58 ¹⁰ | 3,000.00 | 7,231.58 | 341.05% |
| 5533 Property Taxes | 149 | 4,480.22 | 5,000.00 | -519.78 | 89.60% |
| 5534 Furnace Cleaning | 150 | | 400.00 | -400.00 | 0.00% |
| 5535 Pest Control | 151 | 366.60 | 360.00 | 6.60 | 101.83% |
| 5536 Utilities | 152 | | | 0.00 | |
| Electric | 153 | 1,250.17 | 1,043.00 | 207.17 | 119.86% |
| Gas | 154 | 3,531.53 | 3,000.00 | 531.53 | 117.72% |
| Water | 155 | 667.85 | 796.00 | -128.15 | 83.90% |
| Total 5536 Utilities | 156 | \$5,449.55 | \$4,839.00 | \$610.55 | 112.62% |
| 5537 Janitorial Services | 157 | 402.17 | | 402.17 | |
| Total 5530 Trinity House (Rectory) | 158 | \$20,930.12 | \$13,599.00 | \$7,331.12 | 153.91% |
| 5540 Little Dutch Church | 159 | | | 0.00 | |
| 5541 Fire Protection | 160 | | 40.00 | -40.00 | 0.00% |
| 5542 Maintenance & Repairs | 161 | 31,106.16 ¹¹ | 250.00 | 30,856.16 | 12442.46% |
| 5543 Utilities | 162 | | | 0.00 | |
| Electric | 163 | 305.27 | 299.00 | 6.27 | 102.10% |
| Water | 164 | 66.67 | 67.00 | -0.33 | 99.51% |

⁹ Includes \$2170 for the removal of the Annex oil tanks

¹⁰ Includes \$9375 in spending associated with the installation of new windows and repairs to the storm porch.

¹¹ Includes \$30,951 in spending associated with the restoration of the graveyard wall along Brunswick St.

| Income & Expenses 2019 | Line # | Actual | Budget | \$ over Budget | % of Budget |
|--|---------------|-------------------------|---------------------|-----------------------|--------------------|
| Total 5543 Utilities | 165 | \$371.94 | \$366.00 | \$5.94 | 101.62% |
| Total 5540 Little Dutch Church | 166 | \$31,478.10 | \$656.00 | \$30,822.10 | 4798.49% |
| 5550 Round Church | 167 | | | 0.00 | |
| 5551 Janitorial | 168 | | | 0.00 | |
| Janitorial Services | 169 | 4,488.00 | 4,488.00 | 0.00 | 100.00% |
| Janitorial Supplies | 170 | 483.52 | 300.00 | 183.52 | 161.17% |
| Total 5551 Janitorial | 171 | \$4,971.52 | \$4,788.00 | \$183.52 | 103.83% |
| 5552 Maintenance & Repairs | 172 | 22.33 | 2,750.00 | -2,727.67 | 0.81% |
| 5553 Organ Maintenance | 173 | 4,572.64 | 3,300.00 | 1,272.64 | 138.56% |
| 5554 Preservation Expense | 174 | 10,761.75 ¹² | 10,675.00 | 86.75 | 100.81% |
| Fire Alarm Inspection | 175 | 400.00 | 400.00 | 0.00 | 100.00% |
| Fire Protection | 176 | 245.28 | | 245.28 | |
| Furnace Cleaning | 177 | 880.98 | 800.00 | 80.98 | 110.12% |
| Sprinkler Inspection | 178 | 625.00 | 625.00 | 0.00 | 100.00% |
| Total 5554 Preservation Expense | 179 | \$12,913.01 | \$12,500.00 | \$413.01 | 103.30% |
| 5559 Utilities | 180 | | | 0.00 | |
| Electric | 181 | 1,810.62 | 1,672.00 | 138.62 | 108.29% |
| Oil | 182 | 14,050.00 | 9,000.00 | 5,050.00 | 156.11% |
| Water | 183 | 1,493.50 | 1,298.00 | 195.50 | 115.06% |
| Total 5559 Utilities | 184 | \$17,354.12 | \$11,970.00 | \$5,384.12 | 144.98% |
| Total 5550 Round Church | 185 | \$39,833.62 | \$35,308.00 | \$4,525.62 | 112.82% |
| Total 5500 PROPERTY | 186 | \$165,265.77 | \$115,948.00 | \$49,317.77 | 142.53% |
| 5900 Deferred Revenue to Fund Acct | 187 | 3,916.80 | | 3,916.80 | |
| Total Expenses | 188 | \$424,366.10 | \$340,990.00 | \$83,376.10 | 124.45% |
| Net Operating Income | 189 | -\$15,505.83 | \$1,825.00 | -\$17,330.83 | -849.63% |
| Net Income | 190 | -\$15,505.83 | \$1,825.00 | -\$17,330.83 | -849.63% |

Balance Sheet as of December 31, 2019 (Unaudited)

| Balances Year End 2019 | Line # | As of Dec 31, 2019 | As of Dec 31, 2018 | Change |
|--|---------------|---------------------------|---------------------------|--------------------|
| Assets | 191 | | | |
| Current Assets | 192 | | | |
| Cash and Cash Equivalent | 193 | | | |
| 1000 TD/Canada Trust | 194 | 150,308.55 | 124,940.67 | 25,367.88 |
| 1025 Undeposited Funds | 195 | 2,249.00 ¹³ | 0.00 | 2,249.00 |
| Total Cash and Cash Equivalent | 196 | \$152,557.55 | \$124,940.67 | \$27,616.88 |
| Accounts Receivable (A/R) | 197 | 180.00 | 2275.00 | -2095.00 |
| 1200 Petty Cash | 198 | | | 0.00 |
| 1210 Petty Cash (Church Cleaner) | 199 | 300.00 | 300.00 | 0.00 |
| 1220 Petty Cash (Parish Office) | 200 | 300.00 | 300.00 | 0.00 |
| 1230 Petty Cash (Rector's Discretionary) | 201 | 300.00 | | 300.00 |

¹² Includes \$1,570 in maintenance for the HVAC system and \$5,176 to correct deficiencies and repair leaks in the sprinkler system.

¹³ This is the total of rents and other payments received by the parish before December 31, 2019, but deposited into the parish bank account until 2020. This is largely because year-end 2019 fell on a Tuesday, and the parish usually makes deposits on Sundays.

| | Line # | As of Dec 31, 2019 | As of Dec 31, 2018 | Change |
|--|------------|-------------------------|-----------------------|--------------------|
| Balances Year End 2019 | | | | |
| Total 1200 Petty Cash | 202 | \$900.00 | \$600.00 | \$300.00 |
| 1300 Prepaid Expenses | 203 | 0.00 | 0.00 | 0.00 |
| 1310 Prepaid Visa (Office) | 204 | 0.00 | 65.70 | -65.70 |
| Total 1300 Prepaid Expenses | 205 | \$0.00 | \$65.70 | -\$65.70 |
| 1400 Diocesan Endowment Funds | 206 | | | 0.00 |
| 1410 Committed Investments | 207 | | | 0.00 |
| Altar Guild ID840 | 208 | 1,160.20 | 1,049.52 | 110.68 |
| Helen C Johnson Ministry ID825 | 209 | 32,413.64 | 29,321.34 | 3,092.30 |
| Helen Johnson Youth Music ID277 | 210 | 67,739.97 | 61,277.50 | 6,462.47 |
| Little Dutch Church ID845 | 211 | 28,747.85 | 24,990.54 | 3,757.31 |
| Memorial Fund ID850 | 212 | 6,504.35 | 5,624.25 | 880.10 |
| Pickford Choral Scholar ID860 | 213 | 15,660.51 | 14,166.48 | 1,494.03 |
| Preservation & Conservation ID870 | 214 | 337,273.00 | 305,096.75 | 32,176.25 |
| Wright Gravelot Fund [Lot 10] | 215 | 3,024.69 | 2,650.78 | 373.91 |
| Total 1410 Committed Investments | 216 | \$492,524.21 | \$444,177.16 | \$48,347.05 |
| 1420 Uncommitted Investments | 217 | | | 0.00 |
| Rectors & Wardens ID810 | 218 | 21,592.21 | 18,770.16 | 2,822.05 |
| Rectors Fund ID830 | 219 | 11,589.59 | 10,483.93 | 1,105.66 |
| Total 1420 Uncommitted Investments | 220 | \$33,181.80 | \$29,254.09 | \$3,927.71 |
| Total 1400 Diocesan Endowment Funds | 221 | \$525,706.01 | \$473,431.25 | \$52,274.76 |
| Total Current Assets | 222 | \$679,343.56 | \$601,312.62 | \$78,030.94 |
| Non-current Assets | 223 | | | |
| Property, plant and equipment | 224 | | | |
| 1500 Owned Property | 225 | | | 0.00 |
| 1520 Parish Hall - 5421 Cornwallis | 226 | 132,000.00 | 122,100.00 | 9,900.00 |
| 1530 Trinity House - 5435 Cornwallis | 227 | 374,600.00 | 373,200.00 | 1,400.00 |
| 1540 LDC - 2393 Brunswick St. | 228 | 251,200.00 | 251,200.00 | 0.00 |
| 1550 Round Church - 2222 Brunswick | 229 | 1,886,800.00 | 1,886,800.00 | 0.00 |
| 1560 Maitland St Parcel B Halifax | 230 | 127,700.00 | 127,700.00 | 0.00 |
| Total 1500 Owned Property | 231 | \$2,772,300.00 | \$2,761,000.00 | \$11,300.00 |
| Total Property, plant and equipment | 232 | \$2,772,300.00 | \$2,761,000.00 | \$11,300.00 |
| Total Non Current Assets | 233 | \$2,772,300.00 | \$2,761,000.00 | \$11,300.00 |
| Total Assets | 234 | \$3,451,643.56 | \$3,362,312.62 | \$89,330.94 |
| Liabilities and Equity | 235 | | | |
| Liabilities | 236 | | | |
| Current Liabilities | 237 | | | |
| Accounts Payable (A/P) | 238 | 10,312.27 ¹⁴ | 1,931.39 | 8,380.88 |
| 2200 Diocesan Payables | 239 | | | 0.00 |
| Allotment | 240 | 9,138.75 | 0.00 | 9,138.75 |

¹⁴ The large amount recorded here is because year-end 2019 fell on a Tuesday, and the parish usually issues payments on Saturdays.

| Balances Year End 2019 | Line # | As of Dec 31, 2019 | As of Dec 31, 2018 | Change |
|---|---------------|-------------------------------|-------------------------------|--------------------|
| Payroll | 241 | 25,727.10 | 0.00 | 25,727.10 |
| Total 2200 Diocesan Payables | 242 | \$34,865.85 | \$0.00 | \$34,865.85 |
| 2400 ST - funds held for specifics | 243 | | | 0.00 |
| Altar Guild Fund | 244 | 2,170.02 | 3,423.89 | -1,253.87 |
| Archives | 245 | 180.00 | 130.00 | 50.00 |
| Bequests | 246 | 10,088.06 | 10,088.06 | 0.00 |
| Choir Chair Fund | 247 | 888.85 | 888.85 | 0.00 |
| Christmas Outreach Fund | 248 | 3,725.11 | 3,565.07 | 160.04 |
| Curacy Fund | 249 | 2,159.84 | 2,159.84 | 0.00 |
| Deck the Hall - due for transfer | 250 | 0.00 | -223.34 | 223.34 |
| Diocesan Times Fund | 251 | 0.00 | 165.00 | -165.00 |
| Little Dutch Church | 252 | 0.00 | 968.96 | -968.96 |
| Memorials | 253 | 5,790.41 | 9,527.41 | -3,737.00 |
| Mission to Seafarers (Shoeboxes) | 254 | 430.00 | 380.00 | 50.00 |
| Missions Appeal Fund | 255 | 3,262.05 | 3,262.05 | 0.00 |
| Organ Fund | 256 | 1,362.00 | 1,362.00 | 0.00 |
| Outreach (formerly Poor) Fund | 257 | 0.00 | 0.00 | 0.00 |
| Pickford Scholarship | 258 | 4,262.11 | 4,162.53 | 99.58 |
| Preservation ST Fund | 259 | 24,051.72 | 23,286.72 | 765.00 |
| Rector's Discretionary Fund | 260 | 4,080.67 | 1,616.74 | 2,463.93 |
| Soup Kitchen Fund | 261 | 1,511.04 | 1,702.82 | -191.78 |
| Special Gift Fund | 262 | 709.00 | 259.00 | 450.00 |
| YouthNet | 263 | 270.00 | 200.00 | 70.00 |
| Total 2400 ST - funds held for specifics | 264 | \$64,940.88 | \$66,925.60 | -\$1,984.72 |
| 2800 Clearing Suspense | 265 | -303.33 | -303.33 | 0.00 |
| 2900 GST/HST Payable | 271 | 0.00 | 0.00 | 0.00 |
| Total Current Liabilities | 272 | \$109,815.67 | \$68,553.66 | \$41,262.01 |
| Non-current Liabilities | 273 | | | |
| 2500 Liabilities associated with ETF | 274 | | | 0.00 |
| Altar Guild | 275 | 1,160.20 | 1,049.52 | 110.68 |
| Gravelot Fund [Lot 10] | 276 | 3,024.69 | 2,650.78 | 373.91 |
| Helen Johnson Youth Music Trust | 277 | 67,739.97 | 61,277.50 | 6,462.47 |
| HJ Deaf Ministry Fund | 278 | 32,413.64 | 29,321.34 | 3,092.30 |
| Little Dutch Church | 279 | 28,747.85 | 24,990.54 | 3,757.31 |
| Memorial Fund | 280 | 6,504.35 | 5,624.25 | 880.10 |
| Pickford Choral Scholarship | 281 | 15,660.51 | 14,166.48 | 1,494.03 |
| Preservation Fund - Church | 282 | 337,273.00 | 305,096.75 | 32,176.25 |
| Rector & Wardens | 283 | 21,592.21 | 18,770.16 | 2,822.05 |
| Rector's Fund | 284 | 11,589.59 | 10,483.93 | 1,105.66 |
| Total 2500 Liabilities associated with ETF | 285 | \$525,706.01 | \$473,431.25 | \$52,274.76 |
| Total Non-current Liabilities | 286 | \$525,706.01 | \$473,431.25 | \$52,274.76 |
| Total Liabilities | 287 | \$635,521.68 | \$541,984.91 | \$93,536.77 |
| Equity | 288 | | | |

| Balances Year End 2019 | Line # | As of Dec 31, 2019 | As of Dec 31, 2018 | Change |
|-------------------------------------|---------------|-------------------------------|-------------------------------|--------------------|
| 3100 Parish Opening Equity | 289 | 2,772,300.00 | 2,761,000.00 | 11,300.00 |
| Retained Earnings | 290 | 59,327.71 | 58,640.14 | 687.57 |
| Profit for the year | 291 | -15,505.83 | 687.57 | -16,193.40 |
| Total Equity | 292 | \$2,816,121.88 | \$2,820,327.71 | -\$4,205.83 |
| Total Liabilities and Equity | 293 | \$3,451,643.56 | \$3,362,312.62 | \$89,330.94 |

Deck the Hall Committee Year End 2019 Financial Statements

Not available at time of print.

Refugee Sponsorship Committee Year End 2019 Financial Statements

| | | |
|---|-----------|------------------|
| Adjusted bank balance, Dec. 31, 2018 | \$ | 48,064.22 |
| Income 2019 | \$ | 41,922.90 |
| Disbursements 2019 | \$ | 29,357.17 |
| Balance per books Dec.31, 2019 | \$ | 60,629.95 |
| Balance per bank statement, Dec.31, 2019 | \$ | 60,629.95 |
| Plus outstanding deposits | \$ | 257.90 |
| Plus outstanding cheques | \$ | 420.30 |
| Adjusted bank balance Dec. 31, 2019 | \$ | 60,467.55 |

Notes:

| | | |
|---------------|---|-------------|
| Income | Monies from John Maduk, to be held in trust | \$36,000.00 |
| | Donations | \$5,922.90 |
| Disbursements | Monies sent to Uganda | \$1,735.00 |
| | Allowances to family | \$17,050.00 |
| | Settlement costs | \$10,317.05 |
| | Bank charges, cheques | \$255.12 |

Respectfully submitted,

J. de Mestral

Treasurer, Refugee Sponsorship Committee



THE DIOCESAN SYNOD OF NOVA SCOTIA AND PRINCE EDWARD ISLAND

DECLARATION CERTIFICATE NO. NSPE-054

In consideration of the conditions, stipulations and declarations contained herein and the general conditions and riders attached hereto and the premium specified below, the INSURERS, do insure as follows:

CERTIFICATE HOLDER : The Parish of St. George

MAILING ADDRESS OF CERTIFICATE HOLDER : 2222 Brunswick Street
Halifax, NS B3K 2Z3

POLICY PERIOD : From March 1, 2020, until March 1, 2021, at 12:01 a.m. standard time

TOTAL PREMIUM : \$24,234

| <u>SECTION</u> | <u>LIMIT OF LIABILITY</u> | <u>DEDUCTIBLE</u> |
|---------------------------------------|--|--|
| I) PROPERTY OF EVERY DESCRIPTION | As per attached Schedule of Locations | \$5,000 each occurrence, except \$25,000 Flood; 3% / \$100,000 min. Earthquake |
| II) BUSINESS INTERRUPTION | \$100,000 aggregate/occurrence | \$NIL |
| III) COMPREHENSIVE CRIME | | |
| - Employee Dishonesty Form A | \$50,000 | \$500 each occurrence |
| - Inside/Outside Holdup | \$25,000 | \$250 each occurrence |
| - Depositors Forgery | \$25,000 | \$500 each occurrence |
| - Money Orders & Counterfeit Currency | \$25,000 | \$500 each occurrence |
| - Credit Card Fraud | \$25,000 | \$500 each occurrence |
| - Audit Expense | \$25,000 | \$NIL |
| IV) COMMERCIAL GENERAL LIABILITY | \$5,000,000 each occurrence General Aggregate Limit | \$500 Property Damage only, each occurrence |
| POLLUTION LIABILITY | \$2,000,000 | \$1,000 Third Party Property Damage only |
| ABUSE COVERAGE | \$10,000,000 per occurrence \$10,000,000 annual aggregate | \$NIL |
| V) EQUIPMENT BREAKDOWN | Included | \$5,000 each occurrence |

IN WITNESS WHEREOF, ECCLESIASTICAL INSURANCE OFFICE plc has issued a **Master Policy No. 0105122FX01**, but this Certificate shall not be binding upon the Company unless countersigned by a duly authorized representative of the Company.

DIRECTORS' & OFFICERS' LIABILITY: \$2,000,000 per claim subject to an annual aggregate of \$2,000,000 (Including Defense Costs)

RETENTION: \$15,000 for Loss arising from claims alleging the same Wrongful Act or related Wrongful Acts.

IN WITNESS WHEREOF, AIG Insurance Company of Canada has issued a **Master Policy No. 01 66 866 69**, but this Certificate shall not be binding upon the Company unless countersigned by a duly authorized representative of the Company.

| <u>COVERAGE</u> | <u>INSURERS</u> | <u>PARTICIPATION</u> | <u>PREMIUM</u> |
|----------------------------------|-------------------------------------|----------------------|----------------|
| Part I to V Inclusive | Ecclesiastical Insurance Office plc | 100% | \$24,139 |
| Directors' & Officers' Insurance | AIG Insurance Company of Canada | 100% | \$95 |

For purpose of the Insurance Companies Act (Canada), this document was issued in the course of Ecclesiastical Insurance Office plc insurance business in Canada.

Dated: February 27, 2020 at Halifax, Nova Scotia

by, Marsh Canada Limited

THIS POLICY CONTAINS A CLAUSE THAT MAY LIMIT THE AMOUNT PAYABLE

THE DIOCESE OF NOVA SCOTIA AND PRINCE EDWARD ISLAND
SCHEDULE OF INSURED LOCATIONS
(Any Building / Contents not listed here is Not Insured)

Named Insured: The Parish of St. George

Effective: March 1, 2020
Policy No.: NSPE-054

Table with columns: Loc. I.D., Description, Rating Class, Limit per Location, Rate, Premium, Poll Prem, Sub Total. Rows include insured locations like St. George's Church, St. George's Hall, Little Dutch Church, and Parish Rectory, along with summary rows for Total Property Limits and Commercial General Liability Premium.

THE DIOCESE OF NOVA SCOTIA AND PRINCE EDWARD ISLAND

SCHEDULE OF ADDITIONAL INSUREDS AND LOSS PAYEES

Name of Insured: The Parish of St. George

Policy Period: From 01-MAR-2020 to 01-MAR-2021

Coverage is provided for, but not limited to, the following location(s):

| |
|---|
| Location Address: |
| Type: Loss Payee Name: Sharp Electronics of Canada c/o The Bank of New York Mellon Address: 31 Adelaide Street East P.O. Box 104 Toronto, ON M5C 2H8 Special Interest: One MX3550V Digital Imaging System, Value \$12,000 |
| Location Address: |
| Type: Name: Address: Special Interest: |
| Location Address: |
| Type: Name: Address: Special Interest: |
| Location Address: |
| Type: Name: Address: Special Interest: |

Rector's Report

*"Who is weak and I am not weak?"
(2 Corinthians 11:29).*

In his Second Letter to the Christians in Corinth, Saint Paul writes of both the accomplishments and the suffering he endured during his missionary journeys. It was not an easy time, filled with uncertainty and doubt. "Who is weak and I am not weak?" (2 Cor. 11:29) he asks. He rejoices, however, in his failings and weaknesses, because through them the glories of God are seen: his pride no longer obscures his vision of the divine grace. He therefore writes, "If I must needs glory, I will glory of the things which concern mine infirmities" (2 Cor. 11:30).

With the close of 2019, my heart is bursting with joy and gratitude for the accomplishments of the past year and for the opportunity to serve God and neighbour in this place. This is a remarkable parish where God is worshipped and neighbours are cared for in the most incredible ways. Nonetheless, at times I have found myself overwhelmed with the tasks and responsibilities that come with being Rector. In my report I briefly outline some of those things, for your reflection. May God reveal himself to us in our weakness.

Property

During the events marking the 25th anniversary of the fire, we were reminded that in the 1980s the Parish was faced with deferred maintenance of over \$3 million. While this was resolved with the restoration of the church after the fire, it was largely possible because the congregation had already begun the process of restoration years before the fire and had done extensive research about the building. They had no idea how important that information would be in the coming years. A way was made in the wilderness.

Twenty-five years later, the Round Church is beginning to need more substantial repairs, and the Parish Hall and Trinity House are obviously in need of the same. So much has been done, but there is more to do. Our properties are crucial to our ongoing worship and ministry in this neighbourhood and we must recommit ourselves to the care of them now, or we may find ourselves in the same position as we were in the 1980s. We ended the year with a small deficit which is largely due to the upkeep of our buildings (e.g. new windows in Trinity House) and energy costs (e.g. higher than expected heating bills). Our Parish Administrator also spends a considerable amount of his time making repairs to the property which keep him from focusing on other administrative tasks. We need a robust property committee who can oversee larger projects, and a group of dedicated people who will take on the small, daily repairs and upkeep.

Youth and Families

We are blessed with an abundance of children and young families, and we must find ways to strengthen our ministry to them. Meghan Jamieson does an outstanding job as our Sunday School superintendent, but she needs more teachers and helpers. We also need to rebuild our youth group, and, in the longer-term, a number of families have expressed their interest in establishing a day school of some kind for our children. The Parish might consider raising funds to hire a curate or pastoral assistant on a limited-term basis (e.g. two to three years) whose primary responsibility would be in caring for our young people and families. This would also be a way to share the Prayer Book tradition of our parish with a new generation of clergy.

Neighbourhood

A large part of my time this past year was spent working with YouthNet. As Sarah Griffin outlines in her report, there have been considerable changes, including an entire staff turnover and a renewed lunch program. There is much for which we must be thankful, but the YouthNet facilities are in need of upgrade in the next few years to enable this ministry to further flourish.

Our Soup Kitchen remains a strong component of our weekly ministry. I attend as often as I can, at least once or twice a month to speak with the guests and welcome them. Conversations about how we can make this ministry even more hospitable to guests and more attractive for volunteers are underway.

Our grocery card program which operates through the Rector's Discretionary Fund has seen a significant increase this year and at times the need is overwhelming. It is easy to be cynical about this program, but many who are in need say that this program has made them realise that we care about their needs and that they are welcome in the church. Many come to worship throughout the week and on Sundays. The baptisms and the music have been especially healing for some.

Choir and Music

One of the greatest gifts in this parish is the music program, led so ably by our Director of Music. One of the greatest joys for me is that there are street people who come to church in order to hear the choir. There are others in our neighbourhood who want to know more about the musical tradition which this parish has inherited and we need to find ways to raise the profile of our choir and support our Music Director in this work.



Our Music Director Garth MacPhee is the coolest guy.

Thank you

There is an endless list of people to thank, and I only have space to name a few. I must thank our honorary assistant, Father Peter Harris, for his ongoing dedication to the parish and, in particular, his support for me. Father Jim Purchase continues to assist with home visits, and this past year Father Patrick Bright began assisting in this way, too. Father Bright is from Nova Scotia and recently retired to the province with his wife Rhea. During his ministry, he served in a number of parishes in the province and most recently in a Prayer Book Parish in Oklahoma City. Our wardens, Nathan McAllister, Tracy Lenfesty, and Jacquie de Mestral always have the care of the whole parish before them. Our treasurer, Davinia Wright, has sacrificed a lot to keep our books in order and show us how our finances can better support our ministries. Our envelope secretary, Judith Fisher works sacrificially behind the scenes to ensure offerings are properly recorded. One of my greatest joys in this parish comes from working with our Music Director, Garth MacPhee, whose devotion to our liturgical life is an inspiration. Our Parish Administrator, Jordan Gracie, works endlessly at a mountain of tasks. Mary Hills and the Fellowship Teams constantly ensure that this is a hospitable place for everyone. And there are so many more: YouthNet staff, Soup Kitchen volunteers, Altar Guild, the Counters, the Fund Raising teams, the Servers and others who assist at the altar, those who conduct Study Groups and Daily Office Officiants, and so many more.

Conclusion

There is much for which we must give thanks. The Lord is at work in our midst. As a parish, the most important thing you can do to care for me is to care for one another and ask one another for help. Take time to listen and be attentive and give thanks for one another. Greet warmly the street folks who come through our doors, watch out for the children and the elderly, and ask for help and be ready to assist others. We are blessed with an embarrassment of riches in the midst of our weakness.

Father Nicholas Hatt
Rector

Wardens' Report

I was glad when they said unto me, 'We will go unto the house of the Lord'. Ps. 122:1

As we enter our second year with Father Hatt, I believe that we are all thankful for his steady hand at the helm. Your three wardens, Tracy Lenfesty, Nathan McAllister, and myself, have been busy this year, at times extremely so, to be sure, but always grateful for guidance and encouragement from our rector as we attempt to do our best in managing the affairs of the Parish.

Of course, in this we have tremendous help from the many parishioners faithful to the needs and commitments of St. George's. As you read through this year's Annual Report, and I strongly encourage you to do so, you can't help but be impressed by the many volunteers who assist in the myriad programs and happenings in the Parish. All play a vital part in this community of ours, which,

in response to the Gospel of Jesus Christ, the Parish of Saint George offers a unique combination of traditional Anglican worship and a commitment to Inner-City Ministry. Open to the community that surrounds it, Saint George's dares to be shaped by the Inner City, yet seeks to transform our neighbourhood by preaching, in Word and action, the Gospel of Jesus Christ. Come join us in worship, fellowship and outreach ministry.

For those with a head for figures, our financial report for 2019 and proposed budget for 2020 will show you how we attempt financially to carry out our mission, our commitment as a community of Christians in this north end neighbourhood. Davinia Wright, our Treasurer these past two years, Judith Fisher, envelope secretary, Jordan Gracie, bookkeeper, Peter Sproule, finance chair, and Tracy Lenfesty, finance warden have all contributed to this important work. Thank you.

An increase in offerings this year is one sign of the health of the Parish. A tremendous boost in givings to the Rector's Discretionary Fund has permitted us to be more present in our north-end community; by having the means to assist some local residents in meeting basic needs, new relationships have been formed. Also, we have been able to undertake some substantial property items, such as the replacement of all windows and doors in Trinity House (aided also by Edmonds), and in starting work on the restoration of the Little Dutch Church (LDC) cemetery dry stone walls. As custodians of several heritage properties and historical buildings, we must be mindful of the responsibilities this involves.

I have been particularly moved by two happenings this year, both with historical implications. One was the recollections of the devastating fire of June 1994, whose 25th anniversary occurred last year, and the months of discernment afterwards. We have just celebrated the 25th anniversary of the decision to rebuild, with a weekend celebrating the decision to restore the Round Church in all its glory. What a debt we owe to all who had the courage to take on this huge undertaking. It was very moving listening to and reading the recollections of people who lived through these events. I am so profoundly grateful to all those involved.

In the fall of 2018, recognizing the deteriorating state of the 250 year old dry stone walls of the LDC, we commissioned an assessment of these walls. Spring 2019, we applied for and received enough funding from HRM to start the work of restoration. A boundary survey of the church and cemetery, some tree and shrub cutting, and the necessary repairs to the Brunswick Street wall were completed by September. NS Heritage Trust provided funds for the required archeological survey. The boundary survey and archeological survey reports contain fascinating historical material and are available in our Archives. Archival maps and deeds show that the cemetery was established



Vigil after the commemoration of the Last Supper on Maundy Thursday.

on three lots in Dutch Town in 1750-51, that a building owned by one George Nagel was moved onto the Gerrish-Brunswick Street corner in 1756, the spire and 11 additional feet were added in 1760, and the consecration of the LDC occurred on Easter Monday, 1761. Listed in the report, taken from Parish records, are the names of the 1024 persons buried in the cemetery, in addition to those in the three crypts and mass graves underneath the church itself. The last burial, we learn, was performed in the LDC burying ground by Rev. R.F. Uniacke on July 24, 1844, of William Conrad, aged 8 days.

Maintaining our unique heritage properties means that we will always have challenges ahead. Finishing the restoration of the Gerrish Street walls, replacing the furnace in the Round Church, completing the Music Room and other Deck the Hall plans, these property related tasks as well as regular upkeep and maintenance will require hard work and dedication by many. All who are 'handy' please step up and volunteer for the property committee! Our efforts will be appreciated by future generations. And, we will be expressing our gratitude to those whose tremendous efforts in the past have brought us to where we are. We are privileged to be custodians of these heritage buildings and properties. What a debt we owe to those faithful souls who came before.

As I step down after four years as warden, I am aware of how many active people presently in the Parish we should thank for the dedication of their time and talents. A special thank you goes to our Music Director, Garth MacPhee, and all the members of the choir who provide the superb music for our liturgy. A whole team of servers, headed up by Scott Connors, leads us in our services, with the sanctuary so well prepared by the dedicated members of the Altar Guild under Tracy Lenfesty. We are particularly blessed in having retired clergy willing to help at the altar; it is always good to have Fr. Harris, Fr. Purchase and now Fr. Bright in our midst. Mary Hills, our Hospitality Leader, is often asked to do the impossible, which she accomplishes with help from the Fellowship Teams. Under Meghan Jamieson several teachers make sure the children are getting a Christian education. This year we welcomed a family of refugees from Africa; all members of the Refugee Sponsorship Committee, led by Susan Dodd, with members from both our church and St. Patrick's are to be commended for their hard work. Parish Council members faithfully meet once a month, Soup Kitchen leaders and volunteers faithfully show up every six weeks. Our Parish Administrator somehow manages to juggle many tasks. Lay people lead the daily offices each weekday. We have counters and greeters, bell ringers and coffee makers, sextons and cleaners. The list of the Faithful active in the Parish is a long one. Thank you all.

How fortunate we are to have found our spiritual home here at Saint George's Round Church.

Blessed are they that dwell in thy house; they will be always praising thee. Ps.84:4

Jacqueline de Mestral
Senior Warden

With thanks to fellow wardens Tracy and Nathan for friendship, dedication, and encouragement.

Parish Administrator's Report

Summer Student

In 2019, rather than applying for funding for summer students through Canada Summer Jobs, which has been tweaked slightly to emphasize "training in marketable skills," we applied for funding through the Government of Canada's Young Canada Works programme, which, among other things, grants funding to National Historic Sites for the purpose of showcasing those sites to the public.

The Parish hired Aidan Ingalls, and, through the flexibility of the grant, was able to keep the Round Church and Little Dutch Church open to visitors from August until the end of October (the end of cruise-ship season).

The Church received approximately 542 ± 4 visitors and made at least \$125 in sales of souvenirs and donations between August 1 and October 31.

As I have said before, we are about two blocks too far north to be on the beaten path for most visitors to Halifax. This tends to mean that visitors to the Round Church have sought out the building as a place to visit, and want to spend time hearing the parish's stories and exploring the architecture, rather than taking a picture and rushing to the door.

Facilities Management

The parish's buildings continue to see heavy use. The hall routinely plays home to three 12-step programmes (Tuesday evening, Thursday evening, and Tuesday-Friday at noon), three dance groups (tango on Monday evening, Scottish dance on Thursday evening, and Irish dance on Friday and Sunday), an Early Music studio (which uses both the Round Church and the hall), and, of course, our own YouthNet (afterschool programming on schooldays, and full-day camps during the summer).

In addition, we have been sharing our hall with New Horizons Baptist Church as their building undergoes a very exciting redevelopment. We are very fortunate to be able to offer them office space, a place for their weekly bible study, and a piano for the occasional choir rehearsal.

The hall was also host to numerous one-off events in 2019, from neighbouring not-for-profits who needed meeting space, to wedding receptions, to a screening of new films hosted by the Atlantic Filmmakers Co-op. Of particular note are two events: in June, the hall was the venue for the German-Canadian Association of Nova Scotia's "Settler Days" (some of the attendees could trace their ancestry back to parishioners of the Little Dutch Church); and in July, the Round Church was host to the semi-final of the Royal Canadian College of Organists' national organ competition (a three-day event, not including a full day to tune the organ).

Jordan Gracie
Parish Administrator

Director of Music

With pleasure, I submit a report on the Parish Music for the year 2019.

The Junior Choir continues to rehearse on Tuesdays in the Guild Room, 5.30-6.30pm. It is my privilege and delight to teach this cheerful and dedicated group of singers. Their repertoire includes a range of styles, and they have sung in French, German and Latin. A word of appreciation goes to the parents and guardians who ensure that the children arrive punctually for rehearsal, and for their support and encouragement of the choir.

On Sunday, June 16 the Junior Choir presented a Children's Concert in the Round Church. The delightful musical 'A Technicolor Promise' was presented. A large and appreciative audience turned out to support the choir on this occasion. Once again, we were fortunate to call on the theatre expertise of Karen Bassett, who prepared the children for the choreography and staging. Special thanks also to Brenda O'Connor for assisting with the Junior Choir rehearsals. Her enthusiasm and musicality were a tremendous blessing to the choir.

Week by week, the St George's Choir prepares settings of the Ordinary, motets and plainsong psalms for the liturgies. I am grateful to lead such a dedicated and talented group of singers. I wish to thank Andrew Pickett and Jordan Gracie, who from time to time produce wonderful editions of motets and mass settings for the choir's use.

In February, Morag Wilson was awarded the Pickford Choral Scholarship. The bursary was established in 1999 by Karen Westhaver in memory of her mother. It is designated for a young chorister, to provide encouragement in musical pursuits. Morag is currently studying piano and violin, and is a dedicated member of the Parish Choir.

In April, chorister Rebecca Fairless was appointed organ scholar. This was made possible thanks to a generous donation to the music programme. Rebecca is making wonderful progress in her organ playing, both repertoire and service playing.

On Sunday, June 2 a choral evensong was held to mark the 25th anniversary of the fire that badly damaged our beloved Round Church. Music by Weelkes, Tomkins and Gibbons was offered.

In early July, the Royal Canadian College of Organists held their annual convention in Halifax. St George's was the venue for a wonderful lecture recital by Stillman Matheson on July 9th, followed by a choral evensong led by our Parish Choir. The Fall edition of the RCCO's National Journal, *Organ Canada*, included a splendid review of the service, noting 'the eighteen-member parish choir was well tuned, tonally rich, consistent and beautifully matched'. A lovely photo of the choir during the service appeared on the cover of the magazine.

In early September, we rejoiced with Elisabeth and Matthew Stones on the arrival of Baby Phoebe Norah. Elisabeth is much missed in the choir, but we look forward to the day when little Phoebe joins the Junior Choir!

The choir welcomed some talented young singers in the fall: Sopranos Kallie White, Elyse Delaney, Tenor Jeremy Rutledge and Basses, Henk Fischer and Andrew Griffin.

On Sunday, Nov 30 the Music Director led a workshop for parishioners interested in learning to sing Evensong. On three of the four Sundays of Advent this little group gathered to sing the Office, which included plainsong psalms and canticles. On the Second Sunday of Advent, the Parish Choir sang the traditional Service of Lessons and Carols, which was very well received.

The music programme owes a debt of gratitude to the Friends of Saint George's Society for their ongoing efforts on our behalf. Without this support, our music programme would not be able to offer the substance and quality of programming we currently enjoy. Our longsuffering treasurer Steven Burns retired from his duties in October, passing the mantle of responsibility to Justin Wolff. A heartfelt thanks to Steven for his years of dedicated service, and a big thank you to Justin for stepping into the fray.

It's a pure joy working alongside Father Hatt. His sense of humour, wise counsel and liturgical sensibilities are just a few of his admirable qualities. I am thankful for his encouragement and support of the music in our parish.

Garth MacPhee
Director of Music

*Reports from Committees, Subcommittees,
Parish Organizations, and Congregational Bodies*

Spiritual Development

Spiritual Development Committee

On the first four Sundays in Lent, a series of meditations were delivered by parishioners at the regular 5 pm Evensong services. These meditations were offered by Jane Neish, Samuel Landry, David Sheppard and Meghan Jamieson.

The Fourth Sunday in Lent, known as Mothering Sunday or Refreshment Sunday, featured the traditional blessing of simnel cakes which were served following the service at the usual parish potluck in the parish hall.

During Holy Week, meditations at Choral Holy Communion on Holy Monday & Holy Tuesday were given by Jordan Draper, who has since been ordained priest and is serving in the Diocese of Saskatchewan. As always, our all-night vigil from the end of the Maundy Thursday Eucharist until the earliest service on Good Friday provided an opportunity for people to watch and pray with Christ in the starkness of the stripped church or at the beautiful Altar of Repose. On Good Friday at our Three Hour Service, meditations on the Seven Last Words from the Cross were offered by The Rector and at the Easter Vigil, the sermon was given by Father Harris.

In September to November 2019, a Fall Reading Group “Placing the Holy” took place, led by Dr. Wayne Hankey. The three novels under discussion were Graham Greene’s *The Power and the Glory*, Ernest Buckler’s *The Mountain and the Valley* and Charles Williams’ *The Place of the Lion*. We are grateful to Dr. Hankey for these sessions.

Also in the fall, Jan Connors led monthly Bible Studies on lessons from the Book of Common Prayer daily lectionary. We thank Jan for her leadership in this.

During Advent, Garth MacPhee conducted workshops on singing Evensong (“I am a feather on the breath of God”) on three of the Four Advent Sundays, just before Evensong. After these sessions, the participants were able to sing the Evensong which followed. Also at these Sunday Evensongs, meditations were offered by Jan Connors, Ginny Wilmhoff and Justin Wolf.

I convened a meeting of the Spiritual Development Committee on Sunday, October 20, 2019. Its members include: Marilyn Orr, Jan Connors, Ginny Wilmhoff, Garth MacPhee, Father Peter Harris, Susan Dodd, Nathan McAllister, Meghan Jamieson, and Susan Harris. The purpose of the committee is to provide advice to the Rector regarding the growth of the spiritual life of the congregation. This includes scheduling educational opportunities, supporting Sunday School and youth programs, and the music program.

Two of our parishioners, Benjamin Lee and Taunya Dawson, were ordained this year and we rejoice with them as they have now taken up appointments, Benjamin as Rector of Trinity Church, Halifax and Taunya as Rector of Hackett’s Cove.

Some educational programs planned for the coming year include a Lenten series on Christian death using John Behr’s book *The Mystery of Christ: Life in Death*, a Lenten Quiet Day (Saturday, March 21st) on the Rule of St Benedict, an Easter Program on John Climacus’ *The Ladder of Divine Ascent*, and an Advent program on the darkness and “hiddenness” of God.

Father Nicholas Hatt

Altar Guild

The Altar Guild is responsible for preparing the Round Church and the Little Dutch Church for the many services that take place in our churches throughout the year. We have five teams and each team has at least two members. Each week, a team is responsible for polishing the brass communion-rail and other items, washing and preparing the communion vessels, replacing candles, laying out vestments, and arranging flowers (depending on the season of the church year). Some members also wash and iron the small and large altar linens.

As Head of the Altar Guild, I also order communion wine, hosts, candles, and coordinate orders and repairs of vestments and hangings.

In my report for 2018, I explained that we intended to have the green altar-frontal restored in 2019 and would consider purchasing matching vestments. The green frontal was on the altar during the fire that destroyed one-third of the church on June 2nd 1994. Miraculously, it was not badly damaged by fire, smoke, or water, but age had worn holes in the fabric in the past 25 years. The Green Frontal Project became part of our commemoration of the 25th anniversary of the fire.



The restored green altar frontal, which hung on the altar during the fire in 1994

Silk damask was purchased from CM Almy in Maine. Wendy Hunter, a friend of the parish and resident of Oxford, Nova Scotia, very graciously donated her time to restore the green altar-frontal to its former glory with new silk damask and repaired appliques. To thank her for her work and care, the parish purchased and presented Wendy with a hand-woven wool scarf by local artisan Lesley Armstrong of Armstrong Textiles. I would also like to thank all those who made donations to purchase the materials to complete this restoration.

In addition to the restored frontal, and with a donation from the estate of faithful parishioner and altar guild member Barbara Richardson, a new chasuble, dalmatic, and tunicle (with matching stoles and maniples) were purchased. The fabric is matching silk damask. The green frontal and matching vestments were blessed in June 2019 and were used throughout Trinity Season. The church looks quite fresh and glorious with the addition of bright green (rather than a dull grey-green) frontal and vestments.

The next project we will undertake is to restore the purple frontal, which is similar in design to the green. A new green cope would also be a welcome addition to our vestments.

My sincerest thanks and deepest gratitude to all who help with this work: Dinah Savoury, Anne Tilley, Dianna Lowe, Nadine Savoury, Jean Milson, Margherita Mendel, Leona Sweeney, Gabriella Varhelvi, Jim Rawding, Cameron Lowe, and Samuel Landry. New members are very welcome and no experience is necessary.

Tracy Lenfesty
Head of the Altar Guild

Altar Servers

The Servers' Guild consists of a number of individuals who assist with various roles in the Sanctuary during the course of the liturgy. This could be anything from getting the bread and wine or collection from the parishioners who come to the rail with those items at the offertory, carrying the cross to lead processions (crucifer), carrying a candle (taperer) to acting as server by bringing items back and forth between the Altar and Credence table for preparation and clean up of Communion. I produce a schedule that typically has three people scheduled for a 10:30

am Sunday service to perform these roles. I also include someone to act as the Thurifer during High Feast Days or other occasions when incense is used over and above the typical amount we use at a Sunday morning service.

I would like to thank everyone for their continued service throughout the year, especially the following: Raphael Chipman, Richard Kent, Elizabeth Savoury, Suzanne (Sue) Zinck. New members of our team for 2019 include, Teddy Gibson, Rob Speers, Amelia Sproule, Isla Sproule and Ginny Wilmhoff.

Special thanks to Jim Rawding for his continued faithful service at the 8am Holy Communion service on Sunday mornings. As well I would like to thank Ginny Wilmhoff for helping out at Holy Communion services throughout the week such as Wednesday morning at 10am or the services which require a Said Communion service rather than Choral.

We have also lost a few members during the course of 2019. Taunya Dawson is the first who comes to mind as she has gone through the process of becoming a Priest and at the writing of this report has been appointed as Priest in Charge for the Parish of Hackett's Cove. We have also lost Joseph Poon, who was only part of our team for a short time in early 2019, as well as Ulrich (Uli) Vom Hagen, Matthew Vanderkwaak and Trevor Hannon. For the time being Amelia Sproule and Rosemary Wilson have decided to back away from serving on a regular basis and be used to fill in as needed. I would like to thank the above-mentioned people for their service and, in some cases, look forward to their return.

As many of you will know, Andrew Thorne and his family moved to London, Ontario at the end of August last year. His father, the Reverend Gary Thorne, started a three year term at Huron College. Andrew and his family have been back in Halifax on a number of occasions to visit, including during the university summer break. Andrew has served on the altar at Saint George's when he has been in town and I understand that this will continue until Father Thorne's three year term is finished at which time Andrew and his family will return back to Halifax to stay.

We are always looking for people to get involved as part of our team, whether it be one Sunday a month or a few; on high feast days throughout the week; Crucifer at a Choral Evensong, which happens about once a month on Sunday evenings, or all of the above.

Even though our numbers have grown the level of commitment that people can offer varies according to their personal scheduling. The old saying "many hands make light work" holds true here as more people will make it easier to spread the workload to avoid having the same people on week after week and will also provide a mix of new and experienced servers.

Younger children can help as boat boy or boat girl or even help with some of the other duties on the altar. Youth who are in the earlier Sunday School class are also welcome along with anyone who may be preparing for Confirmation. Regardless of age or experience, training can be provided if necessary whether it is briefly before or after a service or during a more convenient time.

At the writing of this report, Cameron Lowe has agreed to be used to fill in as needed and may become part of our regular rotation at some point. Cameron has some experience serving at the Chapel at the University of King's College and is also one of our Parish Sextons.

Respectfully Submitted,

Scott Connors
Head Server

Parish Library

The parish library located off the Guild Room in St George's Church Hall is a treasure trove of great reading! The library's card index of holdings is stored in an unlocked drawer of the glass-doored bookcase and is available to all parishioners. Although most of my activities this past year have been related to the selling of a variety of used books

(donated by parishioners) after the Sunday morning service and in the church hall, I keep a watchful eye on my library space. I have spent 6-8 afternoons, primarily during the summer, cataloguing, shelving, and re-organizing the space as necessary. I attend to the requests of the regular borrowers [Ben, Jacquie, Vaila, and Father Hatt] and avail myself to anyone who would like to use the library's contents. Michal King and I have been running 'Books and More' since September 2016 most Sundays during Fellowship Hour in the church hall. This 'enterprise' evolved naturally from the unsold books leftover after the then annual one day fall book sale in 2013. Our proceeds in 2019 have been over \$4430.00. This includes the June plant sale (\$2400 plus) and the November Christmas sale (\$676). We also see that St George's notecards and LDC pins are available to the public during the summer for sale to tourists who visit St George's. Jordan co-ordinates this effort and proceeds (over \$125 in 2019) go into the general fund.

My thanks to our supporters and generous parishioners for their donations of books and more' for sale, some books of which are pulled for placement into the parish library. The library has recently purchased 2 books associated with St. John the Compassionate Mission that "relate directly to Soup Kitchen and inner city ministry" (Father Hatt).

Respectfully submitted,

Trudie Urquhart
Parish Librarian

Sunday School

We have had a busy year in the Sunday School. In our Spring term our pre-teen group and elementary school group both finished year four of our St George's Curriculum, God's People in the Church. We focused on the lives of Christians in the modern Church for this section, and the children learned about the lives of Christians like Edith Stein, Oscar Romero, and Jean Vanier. This was an inspiring way for the children to finish our teaching cycle, showing how we can live in modern times in an authentic Christian way. They particularly seemed to enjoy seeing photographs and videos of the people we were learning about.

We finished off our Sunday School year with a picnic featuring five kinds of sandwiches and games in the churchyard.

We held a summer camp at the end of August where about 10 children met daily for a week of activities and fun. We had a particular focus on exploring our parish and church, and the activities that go on here. We had a neighbourhood hike, tours of the Little Dutch Church and Round Church, learned about the theology of church architecture, made grave rubbings, wrote a song, learned to play the ukulele, created art, and played a lot of games. I am hopeful we will be able to do this again in the coming summer.

In our new school year we have reverted back to one class after an attempt to maintain our separate pre-teen group. Unfortunately it proved impossible to get a group that was able to meet on a regular basis because of different time commitments. This has left something of a gap for a teen and pre-teen program.

We have now cycled back to year one in our program, which focuses on the catechism. So far, the children have been enjoying learning about their membership in the Body of Christ, and also examining the meaning of the Apostles' Creed. They have created artworks about the Creed, which are hung up in the vestibule of the Sunday School area. As always, the Sunday school depends on parents and volunteers to run successfully. I would like to thank everyone who has helped out with teaching, support, and helping out with our camp: Fr Hatt, Jordan Gracie, Tracy Lenfesty, Carolyn Gibson, Andrea Lee, Benjamin Lee, Vaila Mowat, Rebecca Fairless, Al Wilson, Kieva Diamond, and all the parents who bring their children each week.

Meghan Jamieson
Sunday School Co-ordinator

Pastoral Ministry & Outreach

Christmas Outreach

The Wrap, Pack & Deliver Day took place on Saturday, December 21 in 2019. A happy crew gathered to wrap gifts that morning and a good number of people arrived to help deliver a turkey, grocery cards, and gifts for each of the children in the family.

Christmas Outreach coordinated by Kim Connors.

Deaf Ministry Report

I am happy to report that in 2019 the Deaf Ministry continued at St. George's with three faithful Interpreters interpreting for usually no more than three Deaf parishioners per week. Numbers of the Deaf have dwindled over the past few years, due to death or infirmity, but those who remain make a wonderful addition to our parish life. With the help of our Interpreters (Jessica Bezanson, Ashley Campbell, and Karen Anne Smith), the Deaf are able to participate fully in our 10:30 Sunday morning Choral Holy Communion and in our 10 am Wednesday morning Holy Communion. They are also able to enjoy fellowship events, including fellowship after the Sunday Choral Holy Communion, fellowship after the Wednesday 10 a.m. Holy Communion, as well as potluck meals and other social gatherings. We continue to be grateful to Alan Snook for driving Agnes Comerford to church on Sunday mornings. We are also very thankful to our Interpreters whose work makes this ministry possible for our parish.

Susan Harris
Deaf Support

Fellowship Report

Our fellowship gatherings in the hall following the morning service are always well attended. Parishioners seem to enjoy the time to chat and it is a great way for newcomers to get to know us. The children have fun too. There is a group of dedicated teams who work on a six week rotation who come in early to set things up and provide the food, serve and clear away afterwards. We also get called upon to assist with funeral receptions and special Parish Pot Luck dinners. Some of the team members have been faithful volunteers for many years and for various reasons are having to take a step back. As you know I have recently been requesting more people to come on board or volunteer to provide some extra food. Please let me know if you feel this is something you would like to be part of. Thanks to all who help in any way.

Mary Hills
Fellowship Coordinator

Refugee Sponsorship Committee

Saint George's Refugee Sponsorship Committee is a collaboration among people from St George's Anglican Church, St Patrick's Roman Catholic Church, and community groups from the North End of Halifax. We started when two King's students--Micah Zionce and Samuel Sumner--sought a community to partner with students in response to the Syrian refugee crisis, and we have just kept going.



Tanya displaying her "Angel Gowns." The gowns are given as gifts to the bereaved families of babies who have died too young.

The Saint George's Refugee Sponsorship Committee has been immensely busy this year. Our new family arrived from a refugee camp in Uganda with very short notice--for us and for them--in late July. Through great effort our committee was able to house them temporarily until they moved into a rental home on Quinpool Road near the rotary. That home has been furnished with donations made by members of St George's Parish, St Patrick's Roman Catholic Church, and community donors. The family's arrival was a dramatic reunion of sisters--Daruka Nyantet and Doruka Nicodemus--who hadn't seen each other since they were sent to different refugee camps after fleeing South Sudan in the early 1990s.



Daruka, Akim, and Nybol with their new umbrellas.

The newcomers, the family of Doruka Nyantet, consist of a man and woman, two young men and two little girls. One of the young men, Gabriel, just started at SMU this January. His brother, Emmanuel, is at Citadel High and plays in the local soccer league. One of the girls goes to school, and the other is too young for school and stays at home with her grandparents.

A small group of exceptionally dedicated volunteers, now friends, has been working to help this family settle into life in Canadian winter, to navigate the health care system, and to get to and from appointments and school. It is remarkably challenging... and immensely rewarding.

Should any of you be interested in volunteering with us, we would be delighted to have the help. Especially helpful would be providing drives, or spending time with the girls so their grandmother can work on her English. If you're interested in helping our new family, please don't hesitate to contact either me (Susan.dodd@ukings.ca) or Father Nicholas Hatt. Father Hatt has been especially involved with helping the family to find their feet in this strange and very cold land. Still, we could use helpers in many practical things, and also in friendship and finance. Thank you for all your support to date.

As well, we completed the applications to sponsor another family of six. We will help with the settlement of the mother and family of Doruka Nicodemus' son-in-law, but this will not be for another few years if the government timing is consistent. Filling out these applications is difficult in the most mundane ways, but it is also a bracing reminder of what it means to be a "refugee", what a "civil war" is for mothers and children and older people, and what faith can be and do in tribulation beyond our imagination.

I am in contact with a relative of the Almasalma family to see whether they would like us to proceed with further attempts to bring them to Canada, though at this point, this seems very unlikely. They know that we support them through their bureaucratic nightmare and that we hold them in our prayers.

I do not think I have ever experienced anything as illuminating and humbling as this refugee sponsorship work: the vulnerability of refugees as they hope for resettlement, the resilient faith of our newcomers in the face of mind-boggling cultural, social, economic, and meteorological changes, and the selfless dedication of our committee members are daily inspirations.

Members of the committee this past year included: Susan Dodd, Katie Carline (Chair of the first months after the family's arrival), Jacquie de Mestral (treasurer), Mary Hills, Kieva Diamond, Katie Rains, Bob Doherty, Ian Porter, Sue Zinck, Father Benjamin Lee, and Father Nicholas Hatt. Many others contributed in all kinds of ways. Finally, on behalf of our committee: we are deeply grateful for the service, support, ingenuity, and good humour of Marie Kettle, the Anglican Diocese Director of Refugee Sponsorship.

Susan Dodd
Chair, Saint George's Refugee Sponsorship Committee

Shoebboxes for Seafarers

Fifty well-filled shoebboxes were delivered to the Mission to Seafarers from our church in December, to provide some cheer to the crews of the ships, away from home, and in Halifax for Christmas. This year, as requested by the mission, ten of our boxes were for women. Edmonds also donated fifty great boxes.

A most sincere thank you to everyone who donated shoebboxes, especially the filled ones, items for the boxes and money and to Palma Heming, and Sue and John Smithers for their help in packing and delivering the boxes.

Respectfully submitted,

Patricia Martinson and Anne Tilley

Soup Kitchen

For the past two years, I have used the Soup Kitchen report to communicate basic operational information about the program: how many meals we served, whether the number increased or decreased, where the food came from, and who the team leaders were. I did this because I did not - and do not - see it as my role to comment further. I am a part of the machinery of the church. It is not for me to discern why a program runs. My function is only to keep the program running at the discretion of the parish.

History

Soup Kitchen was originally the brainchild of one of our parishioners, the late Mabel Wainwright, mother of Michal King. Students of the University of King's College served the first meal at Soup Kitchen in the fall of 1985. The aim of Soup Kitchen, in those days, was to supplement Hope Cottage (sponsored by the St. Vincent de Paul Society) by serving supper on Saturdays. In those days, twenty-two organizations, including this parish, shared the responsibility of providing food.

Today, Soup Kitchen is part of a network of meal programmes which, together, offer at least two meals per day, seven days per week on the Halifax peninsula.

Operations

Soup Kitchen served meals to approximately 6245 people in 2019, averaging 122 ± 22 per week (min. 80; max. 176). This represents a small increase from 2018.

Our partnering parishes and organizations in 2019 were:

| | |
|------------------------------------|------------------------------|
| Bedford Baptist | St Margaret of Scotland |
| St Paul's Anglican | St Mark's Anglican |
| All Saints' Cathedral | St John's United, Fall River |
| St Peter's, Birch Cove | St Francis by the Lakes |
| All Saints Bedford | The Halifax Kin Club |
| St Thomas' Anglican, Fall River | The 5th Canadian Division HQ |
| Alpha Gamma Delta alumni | Skinfix Inc. |
| St Patrick's Roman Catholic Church | |

St George's provided 12 meals on its own. Many thanks to the parish volunteers of Team 4, and to Mary Hills, for providing some of those meals.

Soup Kitchen has received \$6000 in capacity-building grants from Feed Nova Scotia over the past two years. That money has paid for new four-foot tables in the upper hall, new tablecloths, repairs to the high-temperature dishwasher to allow it to pass provincial inspection, stainless steel stock pots, and cutlery caddies among other useful items that do not fit within Soup Kitchen's regular operating budget.

Network Standards

As I mentioned in this report last year, Food Banks Canada and Feed Nova Scotia have rolled out a set of Network Standards in an attempt to develop and ensure some consistency in the quality of the services offered throughout the network.

Similar sets of standards to which food banks and meal programs will adhere, and against which such programs will be evaluated, are being implemented across Canada in an attempt to make the network of food banks and meal programs more attractive to an increasingly concentrated donor pool by encouraging transparent operations and promoting best practices.

The application of these Network Standards to our own Soup Kitchen network will have to be a long and careful process of education and encouragement. Soup Kitchen, though it flies under the banner of St George's, is comprised of 15-or-so outside groups and around a hundred volunteers, many of whom have no connection to this parish - or even the Anglican Church - other than a desire to feed the hungry.

In an attempt to determine how best to proceed, I surveyed all of the food providers to determine what steps can be taken to have Soup Kitchen comply with the "food safety" section of these standards. The response, as expected, was all over the board. Sometimes, food for Soup Kitchen is prepared in people's homes, kept in a fridge or, in wintertime, in a garage for a day or so, and then taken to the parish in time for supper on Saturday. Sometimes (more often, I am glad to say, than the previous example), food is prepared and stored in a licensed kitchen under the supervision of someone with FoodSafe Level 1 certification, and then monitored during transport to ensure that the food spends no more than two hours in the "danger zone." Sometimes, and this is something I am trying to encourage, food is made here in our kitchen - though the lack of sufficient cold storage space can make this difficult. Most often, reality falls somewhere between these three examples.

In response to the survey, St Paul's Anglican Church, which had been providing food and volunteers at Soup Kitchen roughly five times per year for as long as I can remember, suspended their support and served their last meal on July 27, 2019. All we can do is thank them for serving with us and wish them well as they discern ways to feed the hungry and clothe the naked who come to their door.

On a hot Saturday morning in August, one of the Provincial Public Health Officers gave a refresher course on food safety. There were 17 attendees from our Soup Kitchen network, including Saint George's. The course was, I think, reasonably well received by those in attendance, though I am sad to say that the vials of foodborne parasites preserved in formaldehyde did not make an appearance.

Final Thought

The census, for all its detail, only reinforces what we intuitively know about this neighbourhood: rents are high, wages are low, and the result is that there are many who go hungry. We should rejoice that some of them trust us enough to come to us for aid, and, for our part, that we are able to ease their burden by one meal per week.

Jordan Gracie
Soup Kitchen Coordinator

SAINT GEORGE'S YouthNet

St. George's YouthNet Annual Report 2019

This past year at St. George's YouthNet has been a time of transition, growth, sad goodbyes, and imagination. All programs have been gifted with new participants, and several of our programs have increased in size over the course of the year. Perhaps most notably, we have welcomed 31 new volunteers to our after-school program, a handful of new community partnerships in our Lunch Program, along with a time for reimagining our Teen Program. This time of transition has given us pause for reflection: it has allowed us to consider how best to fit the current needs of the neighborhood and how we can better hold programming that challenges each child to aspire beyond circumstance and to grow through the supportive community that friendship offers. In all of our programs, we have built more opportunities for mentorship in an attempt to uphold the vision that it is through friendship that we are each inspired to think outside of ourselves and be changed. We are in deep debt and gratitude to all who have invested in this communal vision at YouthNet with their friendship, time, and financial support.

Staff and Board

Rozzi Curran, who acted as Executive Director for a dedicated four years, and Sarah Krahn, former Program Coordinator, both resigned from their positions over the summer. In their respective places, St. George's YouthNet welcomed Sarah Griffin (beginning in May) and Joseph Blackwood (beginning in October). Hannah Griffin accepted the role of Lunch Program Coordinator in September. Nayo Upshaw and Evangeline Freedman acted as Teen Program Coordinators in the spring of 2019, and we welcomed Hannah Mills and Nyon Butros Weyo in their places when the program restarted in January of 2020.

New to the Board this year is Rotimi Adebayo, who has taken on the role of Treasurer, after Davinia Wright's departure from the Board this year. Nathan Singer sadly left the Board this fall as well. Current Board Members are: Fr. Nicholas Hatt (Chair), Tracy Lenfesty, Jacquie DeMestral, Andrew Lacas, Jamie Angus and Rotimi Adebayo (Treasurer).

After-School Program

We have had a steady 22 children enrolled in our after-school program, all of whom bring life, imagination and energy to the program. Throughout the course of the year, we have maintained steady ties with the University of King's College, in our one-on-one tutoring mentoring program. In September, in a similar vein, we began a new one-on-one music mentorship program, where each of our participants is taught an instrument of their choice (piano, drumming, ukulele, etc.) with a volunteer musician. Of particular note, Rebecca Fairless, member of the St. George's choir and Registered Music Therapist, came twice a week throughout the fall to facilitate music workshops and offer lessons that focused on each child's well-being and needs. We have also worked to maintain ties with local organizations and programs such as the North End Library, the George Dixon Centre, and Speedy Kids Skating during the colder months. In the fall, we began a new partnership with Up! Basketball, where several of our youths were mentored by older teenaged youths in their teamwork and basketball skills every two weeks. Remarkably, there are currently 54 volunteers who volunteer their time in one way or another towards the After-School program. We are grateful for all of these volunteers and for the communal vision of friendship, mentorship and commitment that is shared. Particular thanks goes to the Halifax Youth Foundation and the Wellness Fund for supporting the After-School program this year.



YouthNet visits the Centre for Art Tapes to record our new 'YouthNet song'

Teen Program

At the beginning of the year, we had 8 youths enrolled in the Teen Program. Led by Nayo Upshaw and Evangeline Freedman, the program made dinner together, created a partnership with a local Animal Shelter, and visited the Neptune Theatre. Unfortunately, towards March, attendance dwindled and the program came to an end and did not begin again in the fall. Rather, during this time, the Executive Director and Chair engaged in discussions about the program with local organizations and former participants to try and imagine a new start to the program that would best meet the needs and interests of teenagers in the North End. Over the fall, amidst these discussions, the Director and Program Coordinator hired two new Teen Program Coordinators to begin in January 2020. The Halifax Harbourside Rotary Club is to be thanked for their ongoing financial contribution towards our Teen Program.

Lunch Program

In the spring, Sarah Krahn, former Program Coordinator, took on the responsibilities of the Lunch Program Coordinator and delivered lunches to 24 children at Joseph Howe School each day. In September, Hannah Griffin was hired as Lunch Program Coordinator, and worked closely with the Director to imagine healthier and new possibilities for the program. In the fall, we developed new partnerships with local organizations and groups, including LF Bakery, The Nook, University of King's College and Trinity House to contribute towards our monthly roster of lunches. We also recruited many more individuals from the parish and community to make lunch on a monthly basis. This past year, the Lunch Program received its funding primarily from the Department of Community Services.



Bella and Jayla enjoying their YouthNet Lunch

Summer Programming

This summer, YouthNet hired three summer students: Barbara Loppie, Anne Bell and Emma McNiven. Together we planned eight weeks of summer camp and wilderness trips: Business Camp, Creative Cats Camp, Science Camp, Busy Bees, a five-night trip to Cape Chignecto, a Junior Camping Trip and a three-night Canoe trip to Kejimikujik. We had approximately 20 youth enrolled in each of our Halifax-based camps, and 7-10 youth on each of our wilderness and camping trips. The jam-packed summer culminated, as usual, with Extravajam, our annual summer

party, which was well attended by youth, families, the parish, and supporters of YouthNet. Large thanks goes to the Provincial and Federal Summer jobs programs, along with the Segelberg Trust for their financial support of our summer programming.



Hike to Cape Chignecto

Thank-yous

Thank you to all members of the Parish who donate lunch towards our Lunch Program on a regular basis: Tracy Lenfesty, Mary Hills, Deb Dalton, Anne Tilley, Anna Payton, Angela Bennet, Carolyn Gibson, Linda Hewitt, Wayne Hankey, Ginny Wilmhoff, and Susan and Peter Harris. Special thanks goes to Michal King for volunteering her time on Tuesdays to teach Bella and Rico the piano during our music programming. Thanks to Tracy Lenfesty for offering her car every Monday for use during our Tutoring Program at King's. Special thanks to Tracy Lenfesty, Rotimi Adebayo and Jacquie DeMestral who sit on the Board of Directors. Thank you to St. George's Round Church for use of the space each day for all of our programs.

Members of the Parish can continue to support St. George's YouthNet and its programming through prayer, volunteering with one of YouthNet's mentorship opportunities, offering art supplies, technology and instrument donations, and financial support.

Property

Property Committee

Active on committee 2019: Uli vom Hagen (Chair, Jan.-Aug.), Jacquie de M. (Property Warden), Allan Snook, Jordan Gracie (*ad hoc* member).

The mandate of the Property Committee is to be responsible for the maintenance, repair, and upkeep of all Parish buildings and grounds. This includes the Round Church, Parish Hall, Trinity House and the Little Dutch Church and Cemetery. Monies spent on property in 2019 slightly exceeded \$140,000, approximately 40% of all Parish spending. Please see the detailed financial report for breakdown by building and category.

Highlights:

Round Church. Extensive painting was undertaken on the main exterior portion of the church in 2019. Many thanks to Edmonds for this work.



Blessing the Gardens on Rogation Sunday with the Hall and Trinity House (under scaffolding) in the background

*Plans for 2020 include painting of the upper dome and cupola. Quotes are presently being solicited. We have been advised that the oil furnace and boiler will soon need replacing and have been investigating costs of replacement with gas versus continuing with oil. A new system will likely cost upwards of \$70,000.

Parish Hall. The work of Deck the Hall in the music room will be reported elsewhere. In the main hall, redundant furnace grates were removed and replaced with wooden flooring, curtains were installed on the east stage, and much repainting of the walls completed before the Sheppard-Carline wedding in June (thanks to Mary Hills, Allan Snook and Ian Urquhart). As the oil furnace in the Annex no longer functioned, the hot water lines from the new gas furnaces installed in the west end of the Hall were extended to the Annex and the redundant oil tanks were removed. This fits in with future Deck the Hall plans; for the time being the air distribution system is still in use, eventually there will be hot water radiators throughout.

*Plans for 2020 include painting especially in the hallways and stairwells, painting and reflooring in the Guild Room and, hopefully, the refinishing of the main hall floor.

Trinity House. Extensive work was done on the exterior of TH in 2019. All of the old wooden windows were replaced with new vinyl windows, new front and back doors were installed, and extensive work carried out on the front porch, and adjacent shingles and trim. Cost of the windows was split between the Parish and Edmonds, one window was privately sponsored, and Edmonds generously carried out all the work of installation and refinishing. This is a tremendous boon to Trinity House and the comfort of its residents and the future cost of heating.

*Plans for 2020 include painting and plastering in several rooms.



The Little Dutch Church, the original St George's 1756

Little Dutch Church. An application to HRM for funds to restore the Brunswick Street dry stone wall was successful, and a local stone mason, Christopher Whittle of Whittle Works Natural Fieldstone Designs undertook this work in August and September. As well, a survey of the grounds of the LDC building and cemetery was conducted by Thompson Conn Ltd., necessary silviculture work was undertaken by Arbor Plant Health Care, and an archeological survey, required before any work could commence, was undertaken by April MacIntyre and Associates, this latter funded by a grant from NS Heritage Trust. All those who worship at the LDC are grateful to Elizabeth Henderson for her involvement in supplying a dozen more kneelers to the church.

*Plans for 2020 include painting of the floor and repair of the shingles on NW corner. Also, funding for the Gerrish Street walls will be sought from various government agencies.

Caring for our beautiful but old wooden buildings is a challenge. A recent inventory of the buildings has identified several pages of needed repairs, some of which are noted above. Some items will require professional services, but many small jobs could be undertaken by layfolk. Involving more people on this committee is vital to ensure that we provide regular oversight and maintenance. If you are at all 'handy', please consider whether you have some time to serve your Parish in this capacity.

Jacquie de Mestral
Property Warden

Maintenance Tasks and Repairs Needed as of January, 2020

| Building | Location | Problem | Solution |
|---|----------------------------|---|---|
| <i>N.B. Shaded sections will require professional expertise</i> | | | |
| Round Church, interior | nave | peeling gray paint | scrape & paint |
| | chancel | light fixtures broken | repair or replace |
| | pews | #35, #67 | needs middle support, reinforce |
| | pews | #2, #47 front supports wobbly | tighten/add brackets |
| | furnace | | |
| | dome | water damage | check for leaks, in conjunction with painting |
| | crying room | radiator not working | call repair person |
| | East washroom | radiator not working | call repair person |
| | front landing | badly worn | sand and paint/varnish |
| | crypt | water leakage on floor | check for how coming in |
| Round Church, exterior | upper dome | peeling paint | get quotes |
| | cupola | peeling paint | " |
| | Brunswick St. doors | centre crashbars need servicing | find repair person |
| | " | doors not closing well | will need replacing |
| | Brunswick St. entrance | molding on pilasters missing | replace |
| | Brunswick St. entrance | left light access very difficult | replace? |
| Parish Hall | stairways parking lot | scuffed | paint, tread tape lower stairway |
| | music room | high heating costs | insulate pipes to annex |
| | Cornwallis St. entrance | unfinished above door | gyprock over window, paint |
| | " | flooring in bad shape | paint or cover |
| | entrance inside door frame | rough | paint |
| | stairways Cornwallis St. | stairs worn | paint |
| | " | light switches obsolete | replace |
| | Music Room | heat loss from hot water pipes to Annex | insulate |
| | lower landing to SS rm. | flooring rough | paint or cover |
| | landing Guild Rm. | flooring rough | paint or cover |
| | Hall landing | flooring rough | paint or cover |
| | Scouting room landing | flooring rough | paint |
| | SS room landing | flooring rough | paint |
| | SS room landing | Insufficient lighting | replace light fixture |
| | SS room | windows missing clips | replace |
| | " | SS closet door missing hinge | replace |
| | SS kitchen | problem with mice | clean, exterminators |
| | washroom area | freezer blocks use of cubby holes | install plug on E. wall |
| | washroom by window | door doesn't lock | adjustment needed |
| | (Parish Hall) | (washroom by window) | window needs painting |
| | Guild Room | walls unfinished | paint |
| | " | carpet in corner | replace with plywood |

| Building | Location | Problem | Solution |
|----------------------------|------------------------------|--|------------------------------------|
| | " | floor very rough | paint or cover linoleum 20'6"x 17' |
| | Music director's office | wall around window unfinished | paint |
| | Kitchenette | floor very rough | paint or cover 7' x 9'2" |
| | Hallway | floor very rough | paint or cover 33" x 11'4" |
| | Outer door to copier rm. | door needs refinishing | paint |
| | P.A. office | window trim unfinished | paint |
| | Rector's office | needs sprucing up | paint |
| | Scouting Room | holes in wall, ceiling | plaster, paint |
| | YN Playarea | ceiling rough | plaster, paint |
| | Hall floor | in bad shape ~2,000sq. ft. | sand, varnish |
| | parking lot door | trouble closing | reseat |
| | Maitland St. entrance | corner gutter section leaking | replace |
| | main hall lights | very difficult to maintain | replace |
| | machine room entrance | door hard to close | replace middle hinge, oil |
| | | | |
| Little Dutch Church | NW exterior corner | shingles/trim damaged | replace shingles, trim, paint |
| | Gerrish Street walls | wall leaning into sidewalk, falling stones | complete rebuild of walls |
| | raised floor | oil cloth removed, rough surface | paint |
| | | | |
| Trinity House | kitchen cabinets, trim, door | badly scuffed | paint |
| | kitchen | warped sink | replace |
| | kitchen | damaged walls, ceiling | plaster, paint |
| | some upper rooms | water damage (fixed) | paint |
| | exterior gate | rotting wood | repair |
| | path from boardwalk to house | safety issue | safety tape on stepdown |

Deck the Hall

Deck the Hall 2012-2022

A ten-year project to put new life into the parish hall and fit it to serve as the social centre of Saint George's and the home of its outreach programs for many generations to come.

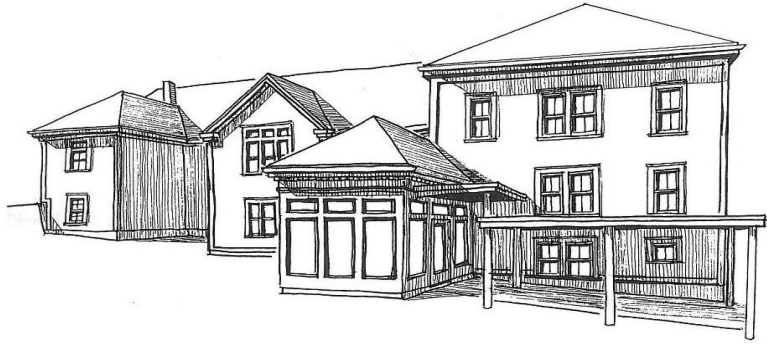

In looking at the header for this report, it appears we're nearing the end of our 10-year window to get this project done! The bad news, as most of you will have observed is that we haven't seen much in the way of actual construction. The good news, which none of you can see, except by way of this report, is that we are still moving forward. Albeit slowly and carefully but there is progress.

Last year's report spoke of the first set of drawings received in January of 2019. The committee was re-established to review the drawings with the hopes of initiating the construction phase of the music room. Upon review and feedback from the committee, there were some oversights flagged for amendment. In particular, the treatment of the ceiling where it meets the windows and lost potential to salvage the stone walls (both things considered to be important features of that space) were noted. We re-engaged the architect for changes to the draft set of drawings which proved to be challenging. In the end, with the support of the wardens and rector, it was determined that we sever the relationship with the architect and move forward in a different way.

Looking at the project with a new lens has given it new life. A short summary of current users of the space, potential users as well as anyone that has solicited the office for current or future rental returned a list of 30+ names and groups. That is very encouraging. Based on some discussions within the committee, it was decided to press forward with the motto 'keep it simple'. The meetings and consultations that we undertook in 2018 were very fruitful in a way. They allowed us to understand the acoustic limitations of the room, provided a set of design ideas that would have it perform as well as possible acoustically and helped us understand what we could realistically achieve in that room. The downside of all the information is that it clouded the overall vision in complicated math, design specifications and limited potential users. In the end, 'keep it simple' is absolutely the way forward.

With that in mind, we have made some headway preparing pricing and quotes for what is left to be done. We got some valuable information from the process with the architect that we can use going forward. There are a few important lessons we've learned throughout this process:

- 1) The shape of the room (a Kleenex box is how it has been described) will never have a rich sound without digital amplification.
- 2) The low ceiling limits how much we can do to help it perform acoustically.
- 3) Most of the sound dampening necessary for foot falls and noise from the hall can only be done from the upper level.
- 4) Accessibility and usability are key components of getting the room complete.

We do have some ideas to share as part of the plan. The main entrance, from the concrete ramp, all the way into the room will be accessible and updated. We hope to restore the stone walls on the North and South side of the room (estimate pending). There will be 1 washroom and one kitchenette/work area adjacent. There will be as much done as possible to dampen sound transmission in and out of the room. It will include acoustic insulation and a specific method of hanging the ceiling. The diagram shown here highlights a dampener that is typically used in applications like these to provide an air gap and decrease vibration transmission (noise) from one area to another.

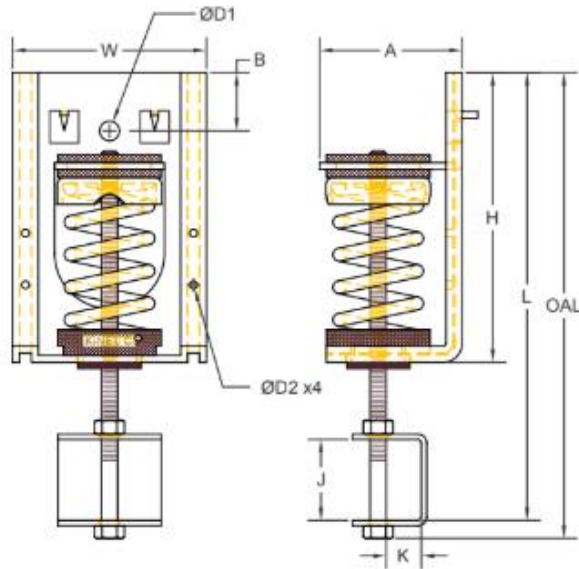

We hope to have pricing for all items of the renovation by the end of March. The next phase will not include finishing the area currently under the hall washrooms (which was initially designated robing/green room/music library). That will be considered at a later time.

I would like to thank the Parish, its parishioners and all members of Deck the Hall committee for their patience in the last two years.

Respectfully submitted on behalf of:

Fr. Nicholas Hatt, *Rector*
 Peter Sproule, *Treasurer*
 Steve Bezanson, *committee member*
 Janet Ross, *committee member*

Jordan Gracie, *Secretary*
 Tracy Lenfesty, *Warden*
 Scott Smith, *committee member*

John Mark Dawson
Chair, Deck the Hall Committee

Trinity House

There have been a great many changes at Trinity House since February last. Over the summer we saw Jane Neish (and Nanuq) head back to Nunavut, and Susan Dodd moved back into her Claremont Street home in late December. It was hard to say goodbye to Susan (and her Lil' Buddy) after so many wonderful years together, but she will be keeping an office on the third floor so as not to disappear completely! Sam Landry (co-sexton) and Joey Blackwood (YouthNet program coordinator) have stuck around, and welcomed Cameron Lowe (co-sexton) and Henk Fischer (chorister; handyman) into the Trinity House family. In addition to the human folk, we have seen the arrival of some of Eden's other inhabitants: Gus the parish cat made his triumphant return to the house under the care of Cameron when his previous owners (former Trinity residents Matthew & Amy) moved to Ireland, Isla the poodle drove back from Virginia with Joey, and energetic lab shepherd Baba came as a package deal with Henk.

Much well-needed work has been done to the house itself—new doors with better weather-proofing, lovely new windows in every room, and vinyl flooring in the mud room, just to name a few. Henk, having just moved in in late December, has already begun taking on painting projects throughout the house, and has many plans to fix up the old rectory!

Sam & Cam share sexton duties, with Cam doing the nightly rounds & bell-ringing, & Sam being responsible for Sunday morning & church hall recycling. Joey, no longer a sexton, has taken on full-time work with YouthNet.

We are all blessed to be a part of the life of this parish, and we thank everyone who helps to make this place feel like home, especially all those who attended & provided dishes for last month's very successful Epiphany party!

Respectfully submitted,

Cameron D.W. Lowe
Co-Sexton

Other Parish Activities and Organizations

Parish Archives

Accessions. There were several accessions of note since my last report.

A recent donation of 21 monthly publications of the *St George's Parish Magazine* from 1897-1899 was received.

A portrait of Adolphus Christoph Vieth, 1754-1835 (right) was received. According to his *Dictionary of Canadian Biography* entry by Terrence Punch:

"Vieth was active in St George's Anglican Church, the successor to the German congregation of the so-called little Dutch church in Halifax... In 1800 he was deputed to accept tenders to construct St George's Round Church, and was receiver of the pew rentals in 1811 and 1812. In 1827 Vieth was one of a group which petitioned successfully to have St Paul's parish divided in two, the northern half to belong to St George's."

Dr. Henry Roper, former Historian/Archivist of St. George's, donated several boxes of manuscripts created during his tenure.

Archival Transfer. A number of memorial plaques were returned to the parish office to be restored and put on display.

Historical Research. The Archivist researched original records at the Nova Scotia Archives for information to assist the Little Dutch Church boundary survey.

Historical Display. A binder of key documents, articles and images was created to commemorate the 25th Anniversary of the Fire.



Respectfully submitted,

Rev'd Taunya J. Dawson, UE, MA, MDiv

Plant Sale & More

Our annual plant sale, May 30, June 1, 2019, raised over \$2,400 for the Parish. This included the sale of plants, pantry items, collectibles and books. It was a great team effort.

Special thanks to Michal King and Trudy Urquhart for organizing all 'non-plant' items, to Edmonds for the donation of annuals, to Maxine Miles and James Rawding who ran the kitchen, to Ada & Wallis Grandy for the pantry table and Martin Yeatman and Lowell Perry for counting. Sincere thanks also to all others who came out to help: Stephen Gibson, Mike West, Rob Speers, Cameron Lowe, Marilyn Orr, Vaila Mowat, Betty Haigh, Elizabeth Henderson, Dinah Savory, Leona Sweeney, Jean Milsom, Janet Ross, Gwynedd & Andrew Pickett, Maddy West & friend, Ginny Salsman, Fr. Purchase, Jordan Gracie, and Fr.Hatt.

The Annual Plant Sale for 2020 is to be held June 5, and 6.

Jacquie de Mestral



Diners enjoying coffee and turkey burgers at the plant sale.

2020 Budget vs 2019 Income & Expense & 2019 Annual Budget

| Budget 2020 | Line # | Budget 2020 | Actual 2019 | Budget 2019 |
|---|-----------|---------------------|---------------------|---------------------|
| Income | 1 | | | |
| 4000 Contributions | 2 | | | |
| 4010 Undesignated Offerings | 3 | 260,269.21 | | 235500 |
| 4011 Direct Deposit | 4 | | 58080 | |
| 4012 Envelope Offerings | 5 | | 174587.2 | |
| 4013 Loose | 6 | | 18099.75 | |
| Total 4010 Undesignated Offerings | 7 | \$260,269.21 | \$250,766.95 | \$235,500.00 |
| 4020 Designated Offerings | 8 | | | 34500 |
| 40201 Altar Guild | 9 | 3,000.00 | 7534.12 | |
| 40202 Archives | 10 | | 50 | |
| 40203 Christmas Outreach | 11 | | 2971.25 | |
| 40204 Deaf Ministry | 12 | 375.00 | 435 | |
| 40205 Diocesan Times | 13 | | | |
| 40206 Memorials | 14 | | 1093.25 | |
| 40207 Mission to Seafarers | 15 | | 50 | |
| 40208 Missions | 16 | | 25 | |
| 40209 Music | 17 | 2,250.00 | 1848.25 | |
| 40211 PWRDF | 18 | | 1020 | |
| 40212 Rector's Discretionary | 19 | | 21340.9 | |
| 40213 Soup Kitchen | 20 | 5,000.00 | 8746.26 | |
| 40214 Special Projects | 21 | | 1452.75 | |
| 40215 Trinity House | 22 | 5,000.00 | 4243.25 | |
| 40216 YouthNet | 23 | | 1035.3 | |
| 40217 Little Dutch Church | 24 | | 1068.96 | |
| Total 4020 Designated Offerings | 25 | \$15,625.00 | \$52,914.29 | \$34,500.00 |
| Total 4000 Contributions | 26 | \$275,894.21 | \$303,681.24 | \$270,000.00 |
| 4100 Earned Revenue | 27 | | | |
| 4110 DNS & PEI Endowment Fund Interest | 28 | | | |
| 4111 Altar Guild | 29 | 50.00 | 44.43 | 50 |
| 4112 Church Preservation Endowment | 30 | 13,000.00 | 12913.01 | 12500 |
| 4113 Deaf endowment | 31 | 1,250.00 | 1241 | 1200 |
| 4114 Pickford Scholarship | 32 | 600.00 | 599.58 | 450 |
| 4115 Rector's Discretionary | 33 | 550.00 | 543.72 | 350 |
| 4116 Youth Music ETF Interest | 34 | 2,600.00 | 2593.52 | 2550 |
| Total 4110 DNS & PEI Endowment Fund Interest | 35 | \$18,050.00 | \$17,935.26 | \$17,100.00 |
| 4120 Rental Income | 36 | | | |
| 4121 Church Rental | 37 | 2,500.00 | 3685.6 | 1650 |
| 4122 Hall Rental | 38 | 9,500.00 | 10865.2 | 8700 |
| 4123 Parking Rental | 39 | 25,000.00 | 26624.5 | 24000 |
| Total 4120 Rental Income | 40 | \$37,000.00 | \$41,175.30 | \$34,350.00 |
| 4130 Miscellaneous Income | 41 | | | |
| 4131 Calendars | 42 | 750.00 | 793.5 | 750 |
| 4132 Fund Raising Sales & Events-net | 43 | 5,000.00 | 4501.35 | 5500 |
| 4133 Grant Income | 44 | 4,650.00 | 31725 | 7200 |
| 4134 HST Income | 45 | 5,117.74 | 8923.62 | 7915 |
| 4135 Church Tours | 46 | | 125 | |
| Total 4130 Miscellaneous Income | 47 | \$15,517.74 | \$46,068.47 | \$21,365.00 |

| Budget 2020 | Line | | | |
|--|-------------|---------------------|---------------------|---------------------|
| | # | Budget 2020 | Actual 2019 | Budget 2019 |
| Total 4100 Earned Revenue | 48 | \$70,567.74 | \$105,179.03 | \$72,815.00 |
| Total Income | 49 | \$346,461.95 | \$408,860.27 | \$342,815.00 |
| Expenses | 50 | | | |
| 5100 GENERAL PARISH EXPENSES | 51 | | | |
| 5101 Allotment | 52 | 26,528.00 | 36555 | 36555 |
| 5102 Anglican Foundation Membership Fee | 53 | 50.00 | 50 | 50 |
| 5103 Archives | 54 | 1.00 | | 1 |
| 5104 Bank Service Charges | 55 | 700.00 | 1111.88 | 700 |
| 5105 GST/HST Expense | 56 | 10,235.49 | 21147.67 | 15000 |
| 5106 Police Record Checks | 57 | 150.00 | 50 | 2500 |
| 5107 Special Events-expenses | 58 | | 409.31 | 1500 |
| 5109 Treasurer & Bookkeeper Stipend | 59 | 4,800.00 | 4800 | 4800 |
| 5120 Office Expenses | 60 | | | |
| 5121 Computers & Equipment | 61 | 1,049.00 | 866.45 | 500 |
| 5122 Office Manager Wages & MERCs | 62 | 1,574.98 | 2256.72 | 4108 |
| 5123 Photocopier Lease/Maintenance | 63 | 4,800.00 | 5040.7 | 4700 |
| 5124 Supplies & Postage | 64 | 2,200.00 | 2034.81 | 1800 |
| 5125 Telecommunication | 65 | 1,880.40 | 1893.34 | 2000 |
| Total 5120 Office Expenses | 66 | \$11,504.38 | \$12,092.02 | \$13,108.00 |
| 5130 Summer Intern/Guide Wages & MERCs | 67 | \$6,021.97 | \$6,364.68 | \$7,600 |
| 5140 Synod Travel & Accommodation | 68 | 50.00 | 50 | |
| Total 5100 GENERAL PARISH EXPENSES | 69 | \$60,040.84 | \$82,630.56 | \$81,814.00 |
| 5200 ORDAINED MINISTRY | 70 | | | |
| 5201 Diocesan Events | 71 | | | 250 |
| 5211 Priest - Assistant Ministry | 72 | 1,200.00 | 1205 | 1200 |
| 5212 Rector's Cell Phone | 73 | 600.00 | 594.87 | 710 |
| 5213 Rector's Housing Allowance | 74 | 23,500.00 | 22500 | 22500 |
| 5214 Rector's Stipend & Benefits | 75 | 35,043.86 | 33499.44 | 32752 |
| 5215 Rector's Travel Reimbursement | 76 | 4,800.00 | 4800 | 4800 |
| 5216 Rector's Vacation Replacement | 77 | 1,500.00 | 370 | 1500 |
| Total 5200 ORDAINED MINISTRY | 78 | \$66,643.86 | \$62,969.31 | \$63,712.00 |
| 5300 PASTORAL MINISTRY | 79 | | | |
| 5310 Christmas Outreach | 80 | | 2811.21 | 2500 |
| 5320 Deaf Ministry Interpreters | 81 | 5,500.00 | 5450 | 5500 |
| 5330 Missions | 82 | | 500 | 500 |
| 5340 Rector's Discretionary Expenses | 83 | | 19420.69 | 6000 |
| 5370 Soup Kitchen | 84 | | | |
| 5371 SK Coordinator/Outreach Support Wages & MERCs | 85 | 14,574.98 | 14256.7 | 14387 |
| 5372 Soup Kitchen Supplies | 86 | 4,800.00 | 9644.42 | 3100 |
| Total 5370 Soup Kitchen | 87 | \$19,374.98 | \$23,901.12 | \$17,487.00 |
| 5390 Transfers to other institutions | 88 | | | |
| St George's YouthNet | 89 | 5,000.00 | 5000 | 5000 |
| PWRDF - disbursed to PWRDF | 90 | | 1020 | |
| Other Transfers | 91 | | 419 | |
| Total 5390 Transfers to other institutions | 92 | 5,000.00 | 6,439.00 | 5,000.00 |

| Budget 2020 | | Line | | | |
|--|--|-------------|--------------------|--------------------|--------------------|
| | | # | Budget 2020 | Actual 2019 | Budget 2019 |
| Total 5300 PASTORAL MINISTRY | | 93 | 29,874.98 | 58522.02 | 36987 |
| 5400 SPIRITUAL DEVELOPMENT | | 94 | | | |
| 5410 General Expenses | | 95 | | | |
| 5411 Advertising | | 96 | 2,000.00 | 1031 | 1500 |
| 5412 Gifts | | 97 | 500.00 | 1398.26 | 500 |
| 5413 Guest Speakers ¹⁵ | | 98 | 0.00 | 75 | 700 |
| 5414 Parish Library ¹⁶ | | 99 | 0.00 | 65.87 | 100 |
| 5415 Prayer Book Calendars | | 100 | 700.00 | 675 | 650 |
| 5416 Lay Readers' Association Fees ¹⁷ | | 101 | 0.00 | 45 | |
| 5417 Special SD Events/Program Costs | | 102 | 1,395.00 | 644 | 250 |
| Total 5410 General Expenses | | 103 | \$4,595.00 | \$3,934.13 | \$3,700.00 |
| 5430 Music Program | | 104 | | | |
| 5431 Music Expenses | | 105 | 2,250.00 | 1485 | 1750 |
| 5432 Musicians | | 106 | 6,500.00 | 6180 | 6000 |
| 5433 Music Director's Stipend | | 107 | 25,459.53 | 25643.24 | 25586 |
| 5434 Music Director's Vacation Replacement | | 108 | 1,200.00 | 760 | 1200 |
| Total 5430 Music Program | | 109 | \$35,409.53 | \$34,068.24 | \$34,536.00 |
| 5440 Sunday School Program | | 110 | | | |
| 5441 Supplies & Materials | | 111 | 250.00 | 75.97 | 250 |
| 5442 Superintendent's Stipend | | 112 | 4,200.00 | 3900 | 4200 |
| Total 5440 Sunday School Program | | 113 | \$4,450.00 | \$3,975.97 | \$4,450.00 |
| 5460 Altar Guild | | 114 | | | |
| 5461 Flowers & Misc. | | 115 | 500.00 | 740.86 | 500 |
| 5462 Liturgical Supplies | | 116 | 5,000.00 | 8342.44 | 2000 |
| Total 5460 Altar Guild | | 117 | \$5,500.00 | \$9,083.30 | \$2,500.00 |
| Total 5400 SPIRITUAL DEVELOPMENT | | 118 | \$49,954.53 | \$51,061.64 | \$45,186.00 |
| 5500 PROPERTY | | 119 | | | |
| 5510 General | | 120 | | | |
| 5511 Insurance | | 121 | 25,070.04 | 20914 | 21000 |
| 5512 Security | | 122 | | | 900 |
| Alarm Monitoring & False Alarms | | 123 | 1,200.00 | 1140 | |
| Sexton's Evening Rounds | | 124 | 500.00 | 883.45 | |
| Total 5512 Security | | 125 | \$1,700.00 | \$2,023.45 | \$900.00 |
| 5513 Fire Protection | | 126 | 150.00 | 35.1 | 150 |
| 5514 Snow Removal | | 127 | 12,800.00 | 11400 | 11000 |
| 5515 Stormwater Charge | | 128 | 111.55 | 113.46 | 250 |
| 5516 Waste Management | | 129 | 1,448.00 | 1244.85 | 1120 |
| 5517 Cost of Generating Rental Income | | 130 | | | |
| Sextons' Event Fees | | 131 | 371.48 | 459 | 300 |
| Total 5517 Cost of Generating Rental Income | | 132 | \$371.48 | \$459.00 | \$300.00 |
| Total 5510 General | | 133 | \$41,651.07 | \$36,189.86 | \$34,720.00 |
| 5520 Parish Hall | | 134 | | | |
| 5521 Janitorial | | 135 | | | |
| Janitorial Services | | 136 | 12,500.00 | 8134.34 | 12000 |

¹⁵ This line item is to be folded into "5417 Special SD Events/Programs" in 2020

¹⁶ This line item is to be folded into "5417 Special SD Events/Programs" in 2020

¹⁷ This line item is to be folded into "5417 Special SD Events/Programs" in 2020

| Budget 2020 | Line | | | |
|---|------------|--------------------|--------------------|--------------------|
| | # | Budget 2020 | Actual 2019 | Budget 2019 |
| Janitorial Supplies | 137 | 1,500.00 | 2104.96 | 1300 |
| Total 5521 Janitorial | 138 | \$14,000.00 | \$10,239.30 | \$13,300.00 |
| 5522 Maintenance & Repairs | 139 | 6,000.00 | 5945.55 | 3250 |
| 5523 Pest Control | 140 | 795.60 | 794.3 | 780 |
| 5524 Furnace Cleaning | 141 | 600.00 | 99 | 600 |
| 5525 Fire Alarm Inspection | 142 | 350.00 | | 350 |
| 5526 Utilities | 143 | | | |
| Electric | 144 | 7,500.00 | 7130.32 | 6385 |
| Gas | 145 | 11,000.00 | 11325.37 | 5700 |
| Water | 146 | 1,350.00 | 1300.23 | 1300 |
| Total 5526 Utilities | 147 | \$19,850.00 | \$19,755.92 | \$13,385.00 |
| Total 5520 Parish Hall | 148 | \$41,595.60 | \$36,834.07 | \$31,665.00 |
| 5530 Trinity House (Rectory) | 149 | | | |
| 5532 Maintenance & Repairs | 150 | 3,000.00 | 10231.58 | 3000 |
| 5533 Property Taxes | 151 | 4,540.02 | 4480.22 | 5000 |
| 5534 Furnace Cleaning | 152 | 400.00 | 0 | 400 |
| 5535 Pest Control | 153 | 367.20 | 366.6 | 360 |
| 5536 Utilities | 154 | | | |
| Electric | 155 | 1,250.00 | 1250.17 | 1043 |
| Gas | 156 | 3,000.00 | 3531.53 | 3000 |
| Water | 157 | 800.00 | 667.85 | 796 |
| Total 5536 Utilities | 158 | \$5,050.00 | \$5,449.55 | \$4,839.00 |
| 5337 Janitorial Services | 159 | 0.00 | 402.17 | |
| Total 5530 Trinity House (Rectory) | 160 | \$13,357.22 | \$20,930.12 | \$13,599.00 |
| 5540 Little Dutch Church | 161 | | | |
| 5541 Fire Protection | 162 | 40.00 | | 40 |
| 5542 Maintenance & Repairs | 163 | 600.00 | 31089.18 | 250 |
| 5543 Utilities | 164 | | | |
| Electric | 165 | 300.00 | 305.27 | 299 |
| Water | 166 | 65.65 | 66.67 | 67 |
| Total 5543 Utilities | 167 | \$365.65 | \$371.94 | \$366.00 |
| Total 5540 Little Dutch Church | 168 | \$1,005.65 | \$31,461.12 | \$656.00 |
| 5550 Round Church | 169 | | | |
| 5551 Janitorial | 170 | | | |
| Janitorial Services | 171 | 4,488.00 | 4488 | 4488 |
| Janitorial Supplies | 172 | | 483.52 | 300 |
| Total 5551 Janitorial | 173 | \$4,488.00 | \$4,971.52 | \$4,788.00 |
| 5552 Maintenance & Repairs | 174 | 2,929.72 | 22.33 | 2750 |
| Fire Protection ¹⁸ | 175 | 245.28 | 400 | |
| Fire Alarm Inspection ¹⁹ | 176 | 400.00 | 245.28 | 400 |

¹⁸ This line item represents a mandatory annual cost. The 2020 budget proposes that this cost be paid out of unrestricted income rather than interest earned on the Round Church Preservation Endowment.

¹⁹ This line item represents a mandatory annual maintenance cost. The 2020 budget proposes that this cost be paid out of unrestricted income rather than interest earned on the Round Church Preservation Endowment.

| Budget 2020 | Line | | | |
|--|-------------|---------------------|---------------------|---------------------|
| | # | Budget 2020 | Actual 2019 | Budget 2019 |
| Furnace Cleaning ²⁰ | 177 | 800.00 | 880.98 | 800 |
| Sprinkler Inspection ²¹ | 178 | 625.00 | 625 | 625 |
| Total 5552 Maintenance & Repair | 179 | 5,000.00 | 2173.59 | 4575 |
| 5553 Organ Maintenance | 180 | 4,500.00 | 4572.64 | 3300 |
| 5554 Preservation Expense | 181 | 13,000.00 | 10761.75 | 10675 |
| 5559 Utilities | 182 | | | |
| Electric | 183 | 1,750.00 | 1810.62 | 1672 |
| Oil | 184 | 12,000.00 | 14050 | 9000 |
| Water | 185 | 1,600.20 | 1493.5 | 1298 |
| Total 5559 Utilities | 186 | \$15,350.20 | \$17,354.12 | \$11,970.00 |
| Total 5550 Round Church | 187 | \$42,338.20 | \$39,833.62 | \$35,308.00 |
| Total 5500 PROPERTY | 188 | \$139,947.74 | \$165,248.79 | \$115,948.00 |
| 5900 Deferred Revenue to Fund Account | 189 | | \$3,916.80 | |
| Total Expense | 190 | \$346,461.95 | \$424,349.12 | \$343,647.00 |
| Net Operating Income | 191 | \$0.00 | -\$15,488.85 | -\$832.00 |
| Net Income | 192 | \$0.00 | -\$15,488.85 | -\$832.00 |

²⁰ This line item represents a mandatory annual maintenance cost. The 2020 budget proposes that this cost be paid out of unrestricted income rather than interest earned on the Round Church Preservation Endowment.

²¹ This line item represents a mandatory annual maintenance cost. The 2020 budget proposes that this cost be paid out of unrestricted income rather than interest earned on the Round Church Preservation Endowment.

Nominations

Leaving, with many thanks for their years of service:

Davinia Wright (Treasurer)
 Marilyn Orr (PC)
 Vaila Mowat (PC)
 Mary Hills (PC)
 Peter Dawson (PC)
 Ginny Wilmhoff (PC)
 Jacquie de Mestral (Warden)

Position

Warden
 Warden
 Warden
 Treasurer
 Secretary

Returning

Tracy Lenfesty (3 of 3)
 Nathan McAllister (2 of 3)
 *
 Jordan Gracie (ex-officio)

Nominated

Meghan Jamieson (1 of 3)

PC Members at large
 (max. 12, 3 yr. terms)

Scott Connors (3 of 3)
 Allan Snook (3 of 3)
 Justin Wolff (2 of 3)
 Alex Bickerton (2 of 3)
 Samuel Landry (2 of 3)
 Steven Gibson (2 of 3)

Sarah Griffin (1 of 3)
 Carolyn Gibson (1 of 3)
 Emily Harnish (1 of 3)
 Ian Porter (1 of 3)
 Peter Bullerwell (1 of 3)
 Mary Hills (1 of 1)

Non-Parish Council Positions

Regional Council Delegates
 Synod Delegates

Wardens
 Sue Zinck (4 of 4)
 Jan Connors (2 of 2)

Youth Synod Delegate
 Auditors (2)

*
 Sarah Stevenson (1 of 1)
 Anne Snook (1 of 1)

Leadership Responsibilities within the Parish (appointed):

| | |
|---------------------------------|-------------------------------------|
| Honourary Assistant | Fr Peter Harris |
| Parish and Hospital Visiting | Fr Jim Purchase, Fr Patrick Bright |
| Spiritual Development Committee | Fr. Nicholas Hatt |
| Property Committee | Jacquie de Mestral, <i>co-chair</i> |
| Deck the Hall Committee | John Mark Dawson |
| Refugee Sponsorship Committee | Susan Dodd |
| Finance Committee | Peter Sproule |
| Altar Guild | Tracy Lenfesty |
| Sacristan | Nadine Savory |
| Server scheduler | Scott Connors |
| Parish Librarian | Trudie Urquhart |
| Envelope Secretary | Judith Fisher |
| Counters | Elizabeth Haigh |
| Hospitality Team Leader | Mary Hills |
| Christmas Outreach | Kim Lickers |
| Shoeboxes for Seafarers | Anne Tilley, Patricia Martinson |
| Safer Church | Fr. Nicholas Hatt & Wardens |
| Publicity | Andrew Pickett |

Submitted by Nominations Committee: Rector, Wardens, Susan Harris

Baptisms, Confirmations, Marriages, and Funerals in 2019

Baptisms

Stephen Schoenmaker
Nicholas Thomas
Bennett Thomas
Avery Wollf
David Wilband
Rosa McAllister
Phoebe Stones

Marriages

Katie Carline & David Sheppard
Anna Howard & Matthew Jacquart
Amanda Simpson & Nathan England

Funerals

Lawrence "Larry" Miles
Kenneth Pringle
Shari Clarke
Michael Tzagarakis
Barbara Smith

Many thanks to those who helped to get this Annual Report printed:

To all those who took time to write the reports in this document,

To Susan Harris for proofreading,

To Susan Harris, Sue Zinck, Tracy Lenfesty and all those who catalogue the life of this parish in photographs, and who have kindly allowed their work to be shown in this Annual Report,

*And to the Rector, Wardens, members of Parish Council,
our Treasurer, Davinia Wright, and the members of the Finance and Budget Committees
for their tireless work on the budget, thoughtful time spent on revisions,
and their commitment to carry the Parish forward in good financial health.*